



SIPI-Benin

TENDER FOR

**SUPPLY OF CARBON STEEL FLANGES AND FITTINGS AT
COTONOU, BENIN OF WEST AFRICA**

TENDER NO. - AIIP/REPL/011/CSF



RESONANCE ENERGY PVT LTD

TENDER DOCUMENT

INTERNATIONAL COMPETITIVE BIDDING

0	31/03/2023	Issued for Bids	DG	PG	AN
Rev	Date	Description	Prepared by	Checked by	Approved by



**SUPPLY OF CARBON STEEL FLANGES AND FITTINGS
AT COTONOU, BENIN OF WEST AFRICA**



Tender Document No:
A IIP /REPL/011/CSF

Date: 31/03/2023

TABLE OF CONTENTS

SECTION - I INVITATION FOR BIDS (IFB)

SECTION - II GENERAL CONDITION OF CONTRACTS (GCC)

SECTION - III SPECIAL CONDITIONS OF CONTRACT (SCC)

SECTION - IV FORMS & FORMATS

SECTION - V SCHEDULE OF RATES (SOR)

SECTION - VI OTHER FORMS APPLICABLE AFTER AWARD



**SUPPLY OF CARBON STEEL FLANGES AND FITTINGS
AT COTONOU, BENIN OF WEST AFRICA**



Tender Document No:
A IIP /REPL/011/CSF

Date: 31/03/2023

SECTION - I
INVITATION FOR BIDS (IFB)



**SUPPLY OF CARBON STEEL FLANGES AND FITTINGS
AT COTONOU, BENIN OF WEST AFRICA**



Tender Document No:
A IIP /REPL/011/CSF

Date: 31/03/2023

1.0 INTRODUCTION

- 1.1** Glo-Djigbe Industrial Zone is being developed as multi-product Industrial Zone in accordance with the vision of republic of Benin to create mass employment opportunities for its population and hence created by Decree N° 2020 -062 DU 05 Fevrier 2020 of Republic of Benin to promote Transformation of Agro-commodities produced in Benin.
- 1.2** Glo-Djigbe Industrial Zone (GDIZ) is a dedicated Zone developed by “Société d’Investissement et de Promotion de L’Industrie – BENIN” (SIPI-BENIN),
- 1.3** SIPI -Benin is jointly promoted by ARISE IIP (Africa Transformation and Industrialization Fund-ATIF) & Africa Finance Corporation (AFC) & Republic of Benin having equity stake of 65% and 35% respectively in the project. At present ARISE IIP made special economic zones in Gabon , Benin and Togo seek to boost exports, enable the local transformation of raw materials and promote trade. Several industrial zones are currently being developed in Togo, Benin, Côte d'Ivoire and Chad.
- 1.4** SIPI-Benin (hereinafter referred as Purchaser) is developing gas infrastructure to supply Piped Natural Gas (PNG) to Industrial consumers at Cotonou, Benin of West Africa.
- 1.5** Resonance Energy Pvt. Ltd. (REPL) has been appointed as the Project Management Consultant by the Purchaser for providing consultancy services for CGD Expansion Project at Benin of West Africa.

2.0 BRIEF DESCRIPTION OF PROJECT

- 2.1** Manufacture, inspection, testing, packing, supply, transportation and unloading of Carbon Steel Flanges & Fittings.

3.0 BRIEF SCOPE

- 3.1** Supply of CS Flanges and Fittings at Benin of West Africa.
- 3.2** For detailed Scope of work and specifications, refer technical specification.

4.0 DISPATCH SCHEDULE-

The Bidder shall make shipment only after obtaining dispatch clearance from Purchaser. For getting dispatch clearance, bidder has to submit inspection release note issued by Third Party Inspection agency to the Purchaser.

- 4.1** Dispatch (Ready for Shipment) of CS Flanges & Fittings shall be within 08 weeks of LOA.
- 4.2** Basis of Delivery : The basis of delivery shall be FOB: Port, country of origin.
- 4.3** PRS Applicability : Date of Bill of Laden (BOL) shall be considered as date of dispatch.

5.0 BID VALIDITY

- 5.1** Bid should be valid for 90 days from the date of schedule submission.

6.0 BIDDING PROCEDURE

- 6.1** Bidding will be conducted through **International Competitive Bidding basis**. Single stage two bid system is adopted for this tender.
- 6.2** Tender document will be shared through e-mail and bidder can also download tender document



**SUPPLY OF CARBON STEEL FLANGES AND FITTINGS
AT COTONOU, BENIN OF WEST AFRICA**



Tender Document No:
A IIP /REPL/011/CSF

Date: 31/03/2023

through Resonance Energy website www.energyworld.biz

6.3 The submission and opening of bids will be through e-mail at sanjay.jain@arisenet.com , aashutosh.a@arisenet.com, kundan.kumar@arisenet.com and prakriti@energyworld.biz

7.0 DETAILS OF BID DOCUMENTS

A.	SUBJECT	SUPPLY OF CARBON STEEL FLANGES AND FITTINGS AT COTONOU, BENIN OF WEST AFRICA
B.	TYPE OF BID	INTERNATIONAL COMPETITIVE BIDDING
C.	TENDER DOCUMENT NUMBER	TENDER NO.: A IIP /REPL/011/CSF
D.	CONTRACT PERIOD	ONE YEAR
E.	PRE-BID MEETING DATE & TIME	07/04/2023 at 15:00 HRS IST , by Video conference Link shall be share shortly by E-mail Pre-Bid Queries shall be received at least two (02) working day prior to the pre-bid meeting date at email id: cp12@energyworld.biz
F.	BID SUBMISSION DATE & TIME	15/04/2023 till 15:00 HRS IST . Bids should be submitted by E-mail as per clause no. 6.3 of IFB
G.	BID SECURITY (EMD)	Not Applicable
H.	BID DOCUMENT FEE	Not Applicable
I.	BID VALIDITY	90 days from the bid due date.
J.	TECHNICAL BID OPENING DUE DATE	15 /04/2023 till 15:30 HRS IST
K.	COMMERCIAL BID OPENING DUE DATE	Date & Time shall be intimated to the technically qualified bidders
L.	ADDRESS FOR CORRESPONDENCE	Mr. Sanjay Jain Procurement Manager Glo-Djigbe Industrial Zone Plot No. F1, National Highway RNIE2 Republic of Benin, West Africa Contact No.: +229-53286261 Mail Id: sanjay.jain@arisenet.com

8.0 BIDDER EVALUATION CRITERIA (BEC)

8.1 TECHNICAL:

8.1.1 The bidder shall be a regular manufacturer of Carbon Steel Flanges and Fittings.

OR

8.1.2 If the manufacturer does not sell his products directly but through his dealer/ distributor/subsidiary, he can authorize a single agency to submit the bid. In such a case the manufacturer shall have the



**SUPPLY OF CARBON STEEL FLANGES AND FITTINGS
AT COTONOU, BENIN OF WEST AFRICA**



Tender Document No:
A IIP /REPL/011/CSF

Date: 31/03/2023

prime responsibility of providing unconditional technical and after sales support to the purchaser. A latest confirmation by the manufacturer to this effect shall be submitted along with the bid.

- 8.1.3** The Bidder should have supplied CS fittings & Flanges of ASTM material Grade of the sizes 4 inch and higher size of minimum 50 quantity in a single order during the last seven years from the bid due date.
- 8.1.4** Bidder is required to furnish the documentary evidence like Purchase Order copies and inspection release note or completion certificate in support of their claim of fulfilling the above required BEC Criteria.
- 8.1.5** Bids are invited from the CS Flanges & Fittings manufacturers. In case, an organization, who owns a separate manufacturing company and keeps their exclusive marketing rights of the product across the globe can also submit the bid. Likewise, a marketing organization owned by a manufacturing organization can also submit the bid. In such case, the manufacturer will give a certificate that they do not quote directly as a matter of policy and they are fully/partly owned by the bidder or vice-versa and the bidder has exclusive marketing right of their product across the globe.

Note :-

- 8.1.6** Either manufacturer or its authorized supplier/dealer can participate against the tender, if the manufacturer and its authorized supplier both submit their bids, the bid submitted by the manufacturer only will be considered for evaluation.
- 8.1.7** Further, one manufacturer can quote only through one sole selling agent / authorized distributor/ authorized dealer/ authorized supply house and a sole selling agent / authorized distributor/ authorized dealer/ authorized supply house shall offer product of only one manufacturer.
- 8.1.8** A job executed by a bidder for its own plant/projects cannot be considered as experience for the purpose of meeting BEC of the tender. However, jobs executed for Subsidiary/ Fellow Subsidiary/ Holding Company will be considered as experience for the purpose of meeting BEC subject to submission of tax paid invoice(s) duly certified by statutory auditor of the bidder towards payments of statutory tax in support of the job executed for Subsidiary / Fellow Subsidiary / Holding Company. Such bidders to submit these documents in addition to the documents specified to meet BEC.
- 8.1.9** For running contract, if the actual executed value/quantity (for partially executed contract) is equal to or more than the value/quantity indicated above one day prior to the due date of bid submission, the same shall also be considered for meeting the single order value/quantity criteria, for which a certificate from the client showing executed value/quantity prior to the due date of bid submission shall be submitted by the bidder along with copy of work order/ agreement.
- 8.1.10** Execution certificate issued by the end user/owner/authorized consultant submitted by a bidder against work contracts can also be considered in place of completion certificate for meeting the stipulated experience criteria provided that the asset for which the said execution certificate has been issued is ready for commercial use.

8.2 Documents Required

The documents required to be submitted by the bidder to substantiate their qualification under Bidder Evaluation Criteria (BEC) shall be as follows:

1. Purchase order (s)/ Work Order (s) defining the complete scope of work.
2. Copy of SOR clearly describing the scope of work.
3. Any other document required for qualification against BEC clauses.

Note

- i. The bidder shall be required to submit the documentation and proof for above BEC requirements and purchaser may make additional checks for the same at his sole discretion.



**SUPPLY OF CARBON STEEL FLANGES AND FITTINGS
AT COTONOU, BENIN OF WEST AFRICA**



Tender Document No:
A IIP /REPL/011/CSF

Date: 31/03/2023

- ii. It shall be noted that in case bidder fails to submit requisite details/ documents, the bid submitted by bidder is liable to be rejected.
- iii. Purchaser/Consultant decision shall be final with respect to bidder's qualification based on bid evaluation criteria.

9.0 TENDER FEE / BID SECURITY

EMD / Bid security has been waived off.

10.0 PRE-BID MEETING

The bidder(s) or their designated representatives, who have downloaded the bid document, or to whom tender document has been issued and who intend to bid are invited to attend the pre-bid meeting. Bidder(s) queries if any, must reach Purchaser at least one day prior to pre-bid meeting date. The pre bid meeting will be organized through video conferencing.

11.0 GENERAL

11.1 Purchaser reserves the right to place the order for part quantity.

11.2 Purchaser reserves the right to split the award.

11.3 The bids received after bid due time/ date shall be rejected.

11.4 Purchaser reserves the right to reject any or all the bids received at its discretion without assigning any reason whatsoever.

11.5 Purchaser/ Consultant will not be responsible for cost incurred in preparation and delivery of bids.

12.0 ELIGIBILITY OF BIDDERS

12.1 Bidders shall as part of their bid, submit a written Power of Attorney authorizing the signatory of the bid to bind the bidder.

12.2 The Bidders shall not be under a declaration of ineligibility for corrupt and fraudulent practices issued by the Purchaser/ Consultant.

13.0 ONE BID PER BIDDER

13.1 Each bidder shall submit only one bid. A bidder who submits or participates in more than one bid will be disqualified. If bid of companies which is managed & controlled by same group of individual (common Purchasers/ proprietor, common partner/ common directors), the participation in a particular tender by more than one such bidder will not be allowed and bids will be disqualified.

13.2 Alternative bids are not acceptable.

13.3 SINGLE POINT RESPONSIBILITIES

The bidder shall submit bid on single point sole/prime bidder responsibility basis. No consortium/ joint bid shall be accepted. The status of all the other vendor(s)/collaborator(s), (if any), referred/identified by the bidder in their offer shall be that of bidder's sub-vendor / supplier/sub- service provider.

14.0 COST OF BIDDING

The Bidder shall bear all costs associated with the preparation and submission of its bid, and the Purchaser/Consultant will in no case, be responsible or liable for those costs, regardless of the



**SUPPLY OF CARBON STEEL FLANGES AND FITTINGS
AT COTONOU, BENIN OF WEST AFRICA**



Tender Document No:
A IIP /REPL/011/CSF

Date: 31/03/2023

conduct or outcome of the bidding process.

15.0 NON-TRANSFERABILITY OF THE BID DOCUMENTS

Bid document is non-transferable. Bid received from the bidders in whose name bid document fee has been submitted shall only be considered. Bidder must submit the bid document fee in their name. Bid document fee shall be submitted by the bidder as defined in tender document.

16.0 CONTENT OF BID DOCUMENTS

16.1 The Bid Documents are those stated below and should be read in conjunction with any corrigendum issued in accordance with clause "AMENDMENT OF BID DOCUMENTS " of Instruction to bidders (ITB).

Volume I : Commercial Volume consisting of :

- Section – I : Invitation for Bids (IFB)
- Section – II : General Conditions (GCC)
- Section – III : Special Conditions of Contracts (SCC)
- Section – IV : Forms and Formats
- Section –V : Forms to be used after award of Contract.
- Volume II : Technical Volume

Schedule of Rates (SOR)

16.2 The Bidder is expected to examine all instructions, forms, terms, and specifications in the bid documents. Failure to furnish all information required by the bid documents or to submit a bid not substantially responsive to the bid documents in every respect will be at the Bidder's risk and may result in the rejection of its bid.

17.0 CLARIFICATION ON BID DOCUMENTS

A prospective bidder requiring any clarification of the Bid Documents may notify the Purchaser and / or the Consultant as the case may be, in writing or by email at the address indicated in the tender/RFQ. The Purchaser will respond in writing to any request for clarification of the bid documents which it receives after issue of the bid documents but prior to at least two (02) working day prior to the pre-bid meeting date. Purchaser will not entertain any queries received after 1800 HRS (IST) post one day of pre-bid meeting. Written copies of the Purchaser's response (including an explanation of the query but not necessarily identifying the source of inquiry) will be hosted on REPL website <http://www.energyworld.biz> along with the corrigendum before the bid due date. All such clarifications issued shall deem to form a part and parcel of the Bid documents.

18.0 AMENDMENT OF BID DOCUMENTS

18.1 At any time prior to the deadline for submission of bids, the Purchaser / Consultant, for any reason, whether at its own initiative or in response to a clarification requested by a prospective Bidder, may modify the bid documents by amendment.

18.2 Any addendum /corrigendum/ clarifications to bidders query thus issued shall be part of the bidding documents pursuant to ITB Clause 8.0 and shall be hosted on the on website www.energyworld.biz and by e-mail before bid due date. All the prospective bidders who have attended the Pre-Bid



**SUPPLY OF CARBON STEEL FLANGES AND FITTINGS
AT COTONOU, BENIN OF WEST AFRICA**



Tender Document No:
A IIP /REPL/011/CSF

Date: 31/03/2023

meeting/ submitted bid document fee, shall be informed by email/ post about the addendum/ corrigendum/ clarifications to bidders query for their reference. Bidders desirous to submit its bid have to take into consideration of all the addendum(s)/ corrigendum (s)/ clarifications to bidders' query hosted on the above websites before submitting the bid.

18.3 In order to allow prospective bidders reasonable time to take care of the addendum/ corrigendum into account in preparing their bids, the Purchaser / Consultant, at its discretion, may extend the deadline for the submission of bids.

18.4 Bidders are advised to visit www.energyworld.biz from time to time to get updated information / documents.

19.0 LANGUAGE OF BID

19.1 The bid prepared and submitted by the Bidder, as well as, all correspondence and documents relating to the bid exchanged by the Bidder and the Purchaser / Consultant, shall be in English.

19.2 In the event of submission of any document/ certificate by the bidder in a language other than English, the English translation of the same duly authenticated by Chamber of Commerce of bidder's country shall be submitted by the bidder along with the bid.

20.0 DOCUMENTS CONSTITUTING THE BID

20.1 The bid prepared by the Bidder shall comprise the following components that are required to be provided:

- Un-priced Techno-commercial bid along with the Bid Forms completed in accordance with the tender documents.
- Price Bid having Price Schedule/SOR filled up in accordance with tender documents.
- Documentary evidence established in accordance with BQC that the goods and ancillary services to be supplied by the Bidder are eligible goods and services and conform to the bid documents; and

21.0 BID PRICES

21.1 The Bidder shall quote Bid Prices on appropriate format of "Schedule of Rates" (SOR) as enclosed part of bid documents as it proposes to supply under the contract.

21.2 Bidder has to indicate price in the "Schedule of Rates" (SOR) separately as under: -

- Unit price including Packing, Forwarding, TPIA charges, inland freight upto port of country of origin.
- Duties & Taxes on above

21.3 The currency exchange rate shall be applicable as of date of bid submission.

22.0 PRICE BASIS

Prices quoted by the bidder shall be considered as firm and fixed during the entire execution of the contract and not subject to variation on any account (except statutory in taxes).

23.0 CURRENCIES OF BID



**SUPPLY OF CARBON STEEL FLANGES AND FITTINGS
AT COTONOU, BENIN OF WEST AFRICA**



Tender Document No:
A IIP /REPL/011/CSF

Date: 31/03/2023

Bidders shall submit bid in **EURO** only.

24.0 DOCUMENTS ESTABLISHING GOOD'S ELIGIBILITY AND CONFORMITY TO BIDDOCUMENTS

24.1 The documentary evidence of the eligibility of the goods and services shall consist of a statement in the Price Schedule of the country of origin of the goods and services offered and a certificate of origin issued at the time of shipment shall confirm the same.

24.2 Wherever appropriate the documentary evidence of conformity of the goods and services to the bid documents may be in the form of literature, drawings, and data, and shall consist of:

- a detailed description of the essential technical and performance characteristics of the goods;
- an item-by-item commentary on the Purchaser/ Consultant's Technical Specifications demonstrating substantial responsiveness of the goods and services to those of the specifications, or a statement of deviations and exceptions to the provisions of the Technical Specifications.

24.3 For purposes of the commentary to be furnished pursuant to ITB above, the Bidder shall note that standards for workmanship, material, and equipment, as well as references to brand names or catalogue numbers designated in the Technical Specifications, are intended to be descriptive only and not restrictive.

25.0 BID SECURITY/ EMD

Bid Security / EMD has been waived

26.0 FORMAT AND SIGNING OF BID

26.1 The bid shall be typed or written in indelible ink. Each page of bid offer shall be stamped and signed by the Bidder or a person or persons duly authorized by competent authority in order to bind the bidder to the contract.

26.2 Any interlineations, erasures, or corrections shall be valid only if the person or persons signing the bid initial them. Overwriting will not be treated as correction and may lead to rejection of bid. A correction shall be considered if a part of text or figures or dates needing corrections are deleted and a separate text or figure or date, as the case may be, is written separately having proper link to the place of correction.

27.0 DEVIATIONS

27.1 Purchaser/ Consultant will appreciate submission of offer based on the terms and conditions in the enclosed GCC, SCC, IFB, Scope of Work, Technical Specification etc. to avoid delay seeking clarifications on technical/ commercial aspect of the offer.

27.2 Deviations if any have to be listed only in the cover letter & Form 2 of the bid submitted by the bidder. Deviations listed anywhere else will not be considered and in case of award of the job to the bidder, the job has to be completed in accordance with the tender terms and conditions without any commercial implications to the Purchaser.

27.3 Notwithstanding to the above, bids with the deviation(s) to the bid conditions shall be summarily rejected without any post bid reference to the bidder. However Purchaser reserves the right to take the final decision in this regard, without assigning any reason

28.0 PREPARATION AND SUBMISSION OF BIDS

28.1 Scanned documents (duly signed by the authorized signatory) and/or pre-formatted excel files to be submitted by the bidder, which shall comprise of the following:

Covering Letter with

- i.** Covering Letter with
- ii.** Bidder's General Information Form 1
- iii.** No deviation confirmation / Deviation Form as per Form 2
- iv.** Format for Certificate from Statutory Auditor for Details of Similar Goods/ Work/ Services Supplied/ Done During Past 5 Years as per Form 3
- v.** Certificate from the Statutory Auditor regarding Supply of Goods/Works/Services as per Form 4
- vi.** Certificates as per Form 5
- vii.** Confirmation that bidder is not banned by any Government organization/ Government Undertaking from quoting as per Form 6
- viii.** Declaration as per Form 7
- ix.** Certificate as per Form 8
- x.** Letter of authority in favour of any one or two of Bidder's executives having authority to attend the un-priced and price bid opening as per Form 9
- xi.** Information regarding any current litigation in which the bidder is involved in Form 10.
- xii.** Contract Cum Performance Bank Guarantee
- xiii.** Power of attorney/Board Resolution of the signatory to the bid document.
- xiv.** Un-priced Schedule of Rates (SOR) should be mentioned as "QUOTED
- xv.** Copy of Company Registration Certificates.
- xvi.** Other documents as per Technical Volume of bid document

28.2 SUBMISSION OF BIDS

- i.** Bid must be submitted through E-mail in two different file attachment.
- ii.** Bidder must attach the following documents in first file attachment
 - a) Covering Letter
 - b) Forms & Format
 - c) Duly signed Tender document
 - d) Un-priced SOR
 - e) BEC technical & financial document
- iii.** Bidder must attach password protected file of Priced- SOR in second file attachment. Bidder must follow below instructions, for submitting password of price bid:
 - a) File must be password protected of twelve (12) characters.



**SUPPLY OF CARBON STEEL FLANGES AND FITTINGS
AT COTONOU, BENIN OF WEST AFRICA**



Tender Document No:
A IIP /REPL/011/CSF

Date: 31/03/2023

- b) Password of Price-bid shall be divided into three parts with individual 4 (four) characters. First part (first 4 character) of password shall be shared to email id: sanjay.jain@arisenet.com, second part (mid 4 character) shall be shared to email id aashutosh.a@arisenet.com , and third part (last four character) shall be shared to email id: kundan.kumar@arisenet.com
- c) Unprotected submission of price bid shall be liable to rejection of bid.

29.0 DEADLINE FOR SUBMISSION OF BIDS

- 29.1** The bid must be submitted through E-mail as specified in IFB not later than the time and date as specified in IFB.
- 29.2** The Purchaser may, in exceptional circumstances and at its discretion, on giving reasonable notice by uploading on website, email or any written communication to all prospective bidders who have been issued the bid document to extend the deadline for the submission of bids in which case all rights and obligations of the Purchaser and bidders, previously subject to the original deadline will thereafter be subject to deadline as extended.

30.0 LATE BIDS

- 30.1** Any bid received by the Purchaser/ Consultant after the deadline for submission of bids prescribed by the Purchaser/ Consultant will be rejected.

31.0 MODIFICATION AND WITHDRAWAL OF BIDS

- 31.1** The Bidder may modify or withdraw its bid after the bid's submission, but before the due date of submission. After the bid due date & time however, no modifications whatsoever are allowed in the bid.
- 31.2** No bid shall be withdrawn in the interval between the deadline for submission of bids and the expiration of the period of bid validity specified by the Bidder on the Bid Form.

32.0 OPENING OF BIDS BY THE PURCHASER/ CONSULTANT

- 32.1** The Purchaser/Consultant will open all bids on online mode in the presence of Bidders' representatives who choose to attend via video conferencing (date & time shall be intimated later).
- 32.2** The Bidders' names, bid modifications or withdrawals, and any such other details as the Purchaser, at its discretion, may consider appropriate, will be announced at the opening. No bid shall be rejected at bid opening, except for late bids.

33.0 REJECTION CRITERIA

- 33.1** Minor unconformities may be neglected and/or bidders may be required to rectify such minor unconformities.
- 33.2** Any deviation/unconformity on following conditions will result in summarily rejection of the bid:
- i) Contract Performance Bank Guarantee as per tender.
 - ii) Period of validity of bid shorter than specified.
 - iii) Price change on account of technical/ commercial clarification and/ or validity extension.
 - iv) Resolution of Dispute/ Arbitration clause.
 - v) Payment terms.
 - vi) Delivery schedule

- vii) Price Reduction Schedule.
- viii) Price not quoted as per SOR
- ix) Warranty / Guarantee
- x) Force Majeure
- xi) Applicable Law
- xii) Scope of Work
- xiii) Any other condition specifically mentioned in the tender documents elsewhere that non-compliance of the clause lead to rejection of the bid

34.0 EVALUATION AND COMPARISON OF BIDS

The Purchaser/ Consultant will evaluate and compare the bids, which have been determined to be substantially responsive.

34.1 Evaluation

The Purchaser will evaluate and compare the bids previously determined to be substantially responsive. In evaluating bids, the Purchaser will determine for each bid the evaluated bid Price by adjusting the bid Price as follows:

- i) Arithmetical errors will be rectified on the following basis:
- ii) If there is discrepancy between the unit rate and the total cost that is obtained by multiplying the unit rate and quantity, the unit rate shall prevail, and the total cost will be corrected.
- iii) If there is a discrepancy between the total bid amount and the sum of total costs, the sum of the total costs shall prevail, and the total bid amount will be corrected.
- iv) Deviations from terms and conditions of the bid document stipulated by the bidder if found acceptable, shall be evaluated and loaded to the quoted price.

Other Conditions Related to Bid Evaluation

- v) Canvassing in any form will make the bid liable for rejection.
- vi) Unsolicited clarifications to the offer and/or change in prices during its validity period would render the bid liable for outright rejection.
- vii) Bidders are advised to ensure that their bids are complete in all respects and conform to our terms, conditions and Bid Evaluation criteria of bid. Bids not complying with Purchaser's requirement may be rejected without seeking any clarifications.
- viii) Bidders will not be allowed to revise their price/bid for any subsequent clarification, compliance to bid conditions after submission of bid.
- ix) Bid should be complete covering the individual item wise total scope of work indicated in the Bid documents.
- x) Price bid will be evaluated as per applicable taxes & duties as on date of Priced bid opening.
- xi) In case if more than one bidder quotes the same rates, then ranking of bidders shall be based on the turnover achieved during the preceding financial year.

34.2 Evaluation and Award Criteria

- xii) The Purchaser/ Consultant will evaluate and compare the bids, which have been determined



**SUPPLY OF CARBON STEEL FLANGES AND FITTINGS
AT COTONOU, BENIN OF WEST AFRICA**



Tender Document No:
A IIP /REPL/011/CSF

Date: 31/03/2023

to be substantially responsive.

- xiii) Prices shall be evaluated **on least cost basis** on CIF: Cotonou, Benin. The prices invited are on FOB basis hence the shipping charges including insurance from FOB port to CIF Cotonou, Benin shall be added on the bid price for final evaluation by Client/Consultant.
- xiv) The evaluated price of bidders shall include the following:
- Unit price including Packing, Forwarding, in-land Freight including Insurance & loading at port. (FOB)
 - Applicable Taxes.

34.3 Bidders are required to quote and comply with all applicable statutory requirements for invoicing.

35.0 CONTACTING THE PURCHASER/ CONSULTANT

35.1 From the time of bid opening to the time of contract award, if any Bidder wishes to contact the Purchaser/ Consultant on any matter related to the bid, it should do so in writing.

35.2 Any effort by a Bidder to influence the Purchaser/ Consultant in its decisions on bid evaluation, bid comparison, or contract award may result in the rejection of the Bidder's bid.

36.0 PURCHASER'S RIGHT TO VARY QUANTITIES DURING THE VALIDITY OF CONTRACT

The Purchaser reserves the right during the validity of contract to increase or decrease the quantity of goods and services originally specified in the Schedule of Requirements without any change in unit price or other terms and conditions.

37.0 PURCHASER'S RIGHT TO ACCEPT OR REJECT ANY OR ALL BIDS

The Purchaser reserves the right to accept or reject any bid in full or part, to annul the bidding process and reject all bids at any time prior to contract award, without thereby incurring any liability to the affected Bidder or Bidders. Purchaser also reserves the right not to accept lowest rates quoted by the bidder.

38.0 NOTIFICATION OF AWARD

38.1 Prior to the expiration of the period of bid validity, the Purchaser will notify the successful Bidder in writing by Letter of Acceptance (LOA) or registered letter or by cable, to be confirmed in writing by registered letter, that its bid has been accepted.

38.2 The date of Letter of Acceptance (LOA / First Intimation for notification of award will constitute effective date.

38.3 The bidder shall promptly, but not later than Seven (7) days of notification of award shall furnish its acceptance of award.

38.4 Upon the successful Bidder's furnishing of the performance Bank Guarantee pursuant to ITB Clause.

38.5 Letter of intent read in conjunction with bid documents shall be binding Contract.

39.0 CORRUPT OR FRAUDULENT PRACTICES

39.1 It is required that all concerned in the entire procurement process to observe the highest standard of ethics during the said process. In pursuance of this policy, the Purchaser/Consultant:

- a. Defines for the purposes of this provision, the terms set forth below as follows:
- i. "corrupt practice" means the offering, giving, receiving or soliciting of anything of



**SUPPLY OF CARBON STEEL FLANGES AND FITTINGS
AT COTONOU, BENIN OF WEST AFRICA**



Tender Document No:
A IIP /REPL/011/CSF

Date: 31/03/2023

value to influence the action of a public official in the procurement process or in contract execution; and

- ii. “fraudulent practice” means a misrepresentation of facts in order to influence a procurement process or the execution of a contract to the detriment of the Borrower, and includes collusive practice among Bidders (prior to or after bid submission) designed to establish bid prices at artificial non-competitive levels and to deprive the Borrower of the benefits of free and open competition;
- b. will reject a proposal for award if it determines that the Bidder recommended for award has engaged in corrupt or fraudulent practices in competing for the contract in question;
- c. will declare a firm ineligible, either indefinitely or for a stated period of time, to be awarded a Bank-financed contract if it at any time determines that the firm has engaged in corrupt or fraudulent practices in competing for, or in executing, a Bank financed contract.

Furthermore, Bidders shall be aware of the provision stated in General Conditions of Contract (GCC).



**SUPPLY OF CARBON STEEL FLANGES AND FITTINGS
AT COTONOU, BENIN OF WEST AFRICA**



Tender Document No:
A I I P /REPL/011/CSF

Date: 31/03/2023

SECTION - III

**GENERAL CONDITIONS OF CONTRACT
(GCC)**



**SUPPLY OF CARBON STEEL FLANGES AND FITTINGS
AT COTONOU, BENIN OF WEST AFRICA**



Tender Document No:
A I I P / R E P L / 0 1 1 / C S F

Date: 31/03/2023

1. DEFINITIONS:

Following definitions shall be applicable for the entire CONTRACT.

AFFILIATE	Shall mean in relation to a Party, any Person that, directly or indirectly, through one or more intermediaries, controls or is controlled by that Party, or is under common control along with that Party. It being understood that the term “control” used herein means ownership by one Person of more than fifty percent (50%) of the voting securities of the other company, or such a Person having the power to direct, administer and dictate the policies of the other company or where such Person has the ability or entitlement to appoint a majority of the Board of Directors of the other Person even where the voting securities held by such a Person exercising such effective control in that other company is less than fifty percent (50%) and the term “Controlled” shall be construed accordingly.
AMENDMENT	Shall mean the addition to and/or the deduction from quantity or scope of work or CONTRACT/Rate validity or any other way of varying the CONTRACT
BOOKS AND RECORDS	Shall mean comprise a Party’s books and records in relation to the matters pertaining to this CONTRACT including, without limitation, its corporate books, bank statements, books of account and supporting documentation (including, without limitation, invoices), whether in paper or other form
CLAIMS	Shall mean liens, claims, judgments, penalties, awards, remedies, debts, liabilities, damages, demands, costs, losses, expenses or causes of action, of whatever nature, including without limitation, those made or enjoyed by dependents, heirs, claimants, executors, Administrators, successors, survivors or assigns.
CONTRACT	Shall mean these GENERAL TERMS of CONTRACT, together with the SPECIAL TERMS of CONTRACT, Letter of Award (LOA) / Purchase Order/ Rate Contract/ Call out Order, including AMENDMENT(s) and all exhibits/ appendices attached hereto and/or incorporated by reference, as originally executed or, as may from time to time, be supplemented or amended in accordance with the Applicable provisions hereof.
CONTRACT PERIOD	Shall mean the period in which CONTRACT shall be valid and in force
CONTRACT VALUE	Shall mean the price payable to the CONTRACTOR under the CONTRACT for the full and proper performance of his contractual obligations and shall be based on the actual GOODS supplied/SERVICES rendered & certified by OWNER and/or Third Party Inspection Agency
CONTRACTOR/SELLER	Shall mean the person, firm, Limited Liability Partnership/Company (LLP/LLC) or company with whom CONTRACT is entered into by the OWNER for providing GOODS/SERVICES. The term includes its legal representatives, successors and assigns.



**SUPPLY OF CARBON STEEL FLANGES AND FITTINGS
AT COTONOU, BENIN OF WEST AFRICA**



Tender Document No:
A IIP/REPL/011/CSF

Date: 31/03/2023

CONTRACTOR GROUP	Shall means the CONTRACTOR and its AFFILIATES, agents and its or their employees, directors and / or officers, legal representatives, Successors and assigns.
CONTRACTOR'S EQUIPMENT	Shall mean any item supplied or used by the CONTRACTOR and/or its SUBCONTRACTORS pursuant to this CONTRACT
CONTRACTOR'S PERSONNEL	Shall mean the employees, directors and / or officers, legal representatives, successors and assigns of the CONTRACTOR GROUP employed, engaged or provided under this CONTRACT
CONTRACTOR REPRESENTATIVE	Shall mean the person appointed from time to time by the CONTRACTOR and notified in writing to the OWNER to act as its representative for the purpose of this CONTRACT or, in absence of such notification, the CONTRACTOR
DELIVERY POINT/SITE	Shall mean the point/location/region for delivery of GOODS and/or execution of SERVICES designated by the OWNER
FORCE MAJEURE	Shall mean act of God, flood, drought, earthquake, cyclone or other disaster, epidemic, plague, fire, act of war or like event which are unpredictable and outside the reasonable control of the affected PARTY, and which could not have been prevented by Good Industry Practice or by the exercise of reasonable skill and care and which, or any consequences of which, have a material and adverse effect upon the performance by the affected PARTY of its obligations under this CONTRACT.
GCC	Shall mean the General Conditions of CONTRACT
GOODS	means the goods/materials specified in this CONTRACT to be supplied by the CONTRACTOR pursuant to and in accordance with the performance parameters & terms of this CONTRACT and complete in all respects to comply with the specifications and requirements stipulated in this CONTRACT
LOCAL TAX	Tax regime applicable to the companies and the operations under this contract in Benin.
LOCAL TAX LAWS	refers to Benin General Tax Code and any other law and decree of application of this code.
GOVERNMENT / GOVERNMENT AUTHORITY	Shall mean the Government of Benin or State Government or any department, authority, ministry, commission, instrumentality, or agency of the Government, or any central, regional, local or municipal authority; any court or governmental tribunal, quasi-judicial or any regulatory authority or any other authority of the Government lawfully exercising jurisdiction over CONTRACT and/or the operations arising out of CONTRACT whether under an Act of Parliament, or any state legislature or otherwise
HSE NORMS	Shall mean the Health, Safety and Environmental (HSE) norms of the OWNER which are to be followed by the CONTRACTOR to ensure safety in the OWNER's business and which are based on generally



**SUPPLY OF CARBON STEEL FLANGES AND FITTINGS
AT COTONOU, BENIN OF WEST AFRICA**



Tender Document No:
A IIP/REPL/011/CSF

Date: 31/03/2023

	accepted standards, procedures and practices in the natural gas Industry.
HSN	Shall mean Harmonized System of Nomenclature, as defined under TAX LAW, for classification of materials for TAX applicability
INTELLECTUAL PROPERTY RIGHTS (IPR)	Shall mean and include any patent, copyright including the copyright in the signage's, registered design/industrial design, trademark (whether or not registered), know-how, Confidential Information or other industrial or intellectual property right presently held or expected to be held by the OWNER under the LAW or under law in any part of the world, including a right to apply for such intellectual property Protection/registration.
OWNER/BUYER	Shall mean SIPI-BENIN (SIPI) having its registered office at Glo-Djigbé Industrial Zone(GDIZ) 201, Building Residence Océane – Block: 612 – District: Patte d'oie – Plot: ZA – 04 BP 612 ☎ +229 21 30 12 13
OWNER GROUP	Shall mean the OWNER and its AFFILIATES, co-ventures, co-licensees and their suppliers other than the CONTRACTOR or agents And its or their employees, directors and / or officers.
OWNER REPRESENTATIVE/ CONTRACT OWNER/ ENGINEER-IN-CHARGE (EIC)	Shall mean the person appointed from time to time by the OWNER and notified in writing to the CONTRACTOR to act as the OWNER's REPRESENTATIVE / CONTRACT OWNER for the purpose of this CONTRACT or, in absence of such notification, the OWNER.
PARTY OR PARTIES	Shall mean the OWNER and the CONTRACTOR collectively referred to as Parties and individually as Party
SCHEDULE OF RATES (SOR)	Shall mean unit rates mentioned in/ attached to CONTRACT agreed between OWNER and CONTRACTOR
SERVICES	Shall mean all required jobs or activities to be executed by the CONTRACTOR as per the scope of work detailed in the CONTRACT
SFMS	Structured Financial Messaging System
SCC	Shall mean the Special Conditions of CONTRACT
SUBCONTRACTOR	Shall mean the subcontractors, consultants, suppliers, intermediaries and any other person providing services to or acting on behalf of CONTRACTOR who are involved in matters pertaining to this CONTRACT

2. GENERAL:

- 2.1 The General Conditions of CONTRACT (GCC) shall be read in conjunction with all other parts of the CONTRACT including the Scope of Work, Technical Specifications, Schedule of Rates (SoR), Drawings and any other exhibits, annexures, appendices, attachments, guidelines & any other documents forming part of, or referenced in the CONTRACT, wherever the

contextso requires.

- 2.2 Notwithstanding the sub-division of the CONTRACT documents into separate sections and volumes, every part of each shall be deemed to be supplementary to and complementary of every other part and shall be read with and into the CONTRACT.
- 2.3 In case of contradiction between any of the CONTRACT documents, the following shall prevail in order of precedence:
 - a. Schedule of rates (SOR)
 - b. Technical Scope & Specifications
 - c. Special Condition of CONTRACT (SCC)
 - d. General Condition of CONTRACT (GCC)
 - e. International Standards & Codes
- 2.4 Wherever it is mentioned in the CONTRACT that the CONTRACTOR shall perform certain work or provide certain facilities, it is understood that the CONTRACTOR shall do so at his cost and the unit rates in CONTRACT shall be deemed to have included cost of such performance and provisions, so mentioned.
- 2.5 Generally, the materials, design, and workmanship shall satisfy the relevant International Standards, the Specifications & scope of work contained herein, and codes referred to. Where the job specifications stipulate requirements in addition to those contained in the standard codes and specifications, these additional requirements shall also be fulfilled.
- 2.6 It will be the CONTRACTOR's responsibility to bring to the notice of the OWNER REPRESENTATIVE, any conflict in the CONTRACT documents before acceptance of the CONTRACT or commencement of any activities under the CONTRACT, with references for which the conflict exists.
- 2.7 In the absence of any specifications covering any material, design or scope of work, the same shall be performed / supplied / executed in accordance with Standard Engineering Practices as per the instructions / directions of the OWNER REPRESENTATIVE, which will be binding on the CONTRACTOR.
- 2.8 In CONTRACT documents, unless otherwise stated specifically, the singular shall include the plural and vice versa wherever the context so requires.
- 2.9 All headings, subtitles and notes in any part of CONTRACT documents are solely for the purpose of giving a concise indication and not a summary of the contents thereof, and they shall never be deemed to be part thereof or be used in the interpretation or construction thereof.
- 2.10 The terms fully capitalized and/or initial capitalized shall be interchangeable and shall have the meaning as assigned to fully capitalized term or initial capitalized term.
- 2.11 The OWNER shall not be bound by any printed conditions or provisions in the CONTRACTOR's quotation, bid forms or acknowledgment of CONTRACT, invoices, packing list, or any other documents, submitted at any stage before or after the award of the CONTRACT, which imposes any conditions at variance with or supplemental to CONTRACT.
3. SCOPE OF WORK:
 - 3.1 The Scope of Work shall be as specified in the CONTRACT. The CONTRACTOR shall provide all necessary services/materials, equipment, labour, etc. for execution & maintenance of work till completion unless



**SUPPLY OF CARBON STEEL FLANGES AND FITTINGS
AT COTONOU, BENIN OF WEST AFRICA**



Tender Document No:
A I I P / R E P L / 0 1 1 / C S F

Date: 31/03/2023

otherwise specified in the CONTRACT.

4. THE CONTRACTOR'S PERFORMANCE:

- 4.1 The CONTRACTOR has represented to have requisite expertise in the provision of the SERVICES/GOODS and the OWNER is at all times relying on the skill, knowledge and workmanship of the CONTRACTOR.
- 4.2 The CONTRACTOR shall be deemed to have read all documentation relating to the CONTRACT in order to determine the type, quantity and quality of resources including personnel that will be required to provide the SERVICES/GOODS and the CONTRACTOR shall obtain for itself a full understanding and knowledge of the nature and scope of the SERVICES/GOODS to be supplied and of the conditions set out in CONTRACT.
- 4.3 The CONTRACTOR shall provide the SERVICES/GOODS free of any defect, deficiency or omission of any kind and with diligence and in a thoroughly workmanlike manner to the satisfaction of the OWNER and to the highest standards of skill and care, generally accepted for performing services of a similar nature. The CONTRACTOR shall ensure that the SERVICES/GOODS comply with and meet the requirements of any applicable legislation.
- 4.4 The CONTRACTOR and/or CONTRACTOR'S personnel shall be responsible and are fully aware of and abide by all the provisions of the CONTRACT that relate to them and the CONTRACTOR shall be entirely responsible for the compliance by the CONTRACTOR'S personnel with the provisions of the CONTRACT. The CONTRACTOR shall adhere to, and shall ensure that all the CONTRACTOR'S personnel are aware of, and comply with all legislations and the OWNER's policies and procedures, as amended from time to time, including those affecting the health, safety and environmental aspects of the SERVICES/GOODS supplied.
- 4.5 The CONTRACTOR shall act as an independent CONTRACTOR and neither the CONTRACTOR nor its employees shall be, nor deemed to be, either expressly or impliedly, treated employees of the OWNER. The CONTRACT does not create any partnership agreement between the OWNER and the CONTRACTOR.
- 4.6 The OWNER shall have the right to object to and require the CONTRACTOR to remove forthwith any of the CONTRACTOR'S REPRESENTATIVE / PERSONNEL who, in the opinion of the OWNER, misconduct themselves by any manner including, but not limited to, committing fraud or any malpractice or are incompetent or negligent or undisciplined in the proper performance of their duties or fail to comply with any provisions of the CONTRACT, or persist in any conduct which is Prejudicial to health, safety or environment, or whose presence is otherwise considered by the OWNER to be undesirable. Such person shall not be employed again upon the SERVICES without the prior written consent of the OWNER. Any person so removed from the SERVICES shall be replaced by the CONTRACTOR within 24 hours by other suitable qualified and experienced CONTRACTOR'S PERSONNEL approved by the OWNER. The CONTRACTOR shall not be entitled to any payment or reimbursement of costs arising from OWNER's such instruction to remove any of the CONTRACTOR'S PERSONNEL.
- 4.7 Transportation of all items covered in the scope of the CONTRACT, i.e OWNER'S free issue materials & the materials to be supplied by the



**SUPPLY OF CARBON STEEL FLANGES AND FITTINGS
AT COTONOU, BENIN OF WEST AFRICA**



Tender Document No:
A IIP/REPL/011/CSF

Date: 31/03/2023

CONTRACTOR, as applicable, will be arranged by CONTRACTOR at his own cost including insurance, storage, handling, transportation etc. CONTRACTOR will also be responsible for taking delivery of free issue material from OWNER'S designated warehouses and transportation to place of work, including its coverage for transit insurance.

- 4.8 The CONTRACTOR shall make his own arrangement for the accommodation & medical assistance to CONTRACTOR'S PERSONNEL at respective locations and subsequent transportation / conveyance arrangement for them from their place of residence to work place or any other place as required, unless specifically agreed by the OWNER in writing, and the OWNER shall have no obligation in this respect. The OWNER shall not be responsible for providing any medical assistance to the CONTRACTOR'S PERSONNEL.
- 4.9 The CONTRACTOR shall arrange for the gate pass & valid identity cards for CONTRACTOR'S PERSONNEL, as per design approved by OWNER, wherever required, at CONTRACTOR's cost. The CONTRACTOR'S PERSONNEL shall be required at all times to carry their respective Identity Cards while on duty and produce on demand. The CONTRACTOR shall provide from time to time a list of the personnel with names, and their brief work profile, whenever demanded by OWNER.
- 4.10 The CONTRACTOR shall comply in all respects to the timelines specified in the CONTRACT or as intimated by OWNER REPRESENTATIVE. The CONTRACTOR agrees to comply strictly with such scheduling and co-ordination. OWNER reserves the right and authority to reasonably schedule and reschedule the supply of SERVICES/GOODS to effect overall execution of the CONTRACT, including the express right and authority to direct additional manpower, equipment or any other resources, of which the SERVICES/GOODS form part of, and any overtime reasonably necessary to accomplish its obligations hereunder, provided, however, that such reserved right and authority may be exercised only by the express direction in writing by the OWNER, without any additional cost to OWNER. The CONTRACTOR shall promptly submit to the OWNER such schedules and reports pertaining to the CONTRACTOR'S performance of the SERVICES at the time and in the form required by OWNER.
- 4.11 The CONTRACTOR shall execute any work as may be necessary in respect of rectification of defective SERVICES/GOODS, as may be required of the CONTRACTOR in writing by the OWNER.
- 4.12 If the CONTRACTOR fails or is unable, within a reasonable time, to provide the SERVICES /GOODS or to execute any work as may be necessary in respect of rectification of defective SERVICES/GOODS, OWNER shall be entitled to perform itself or employ and pay third parties to carry out the required work and if such work comprises the SERVICES/GOODS which, in the opinion of OWNER, CONTRACTOR was liable to do at its own expense under the CONTRACT, then all such expenses, incurred by OWNER as a result of CONTRACTOR's failure or inability to so provide the SERVICES/GOODS, shall be recoverable from the CONTRACTOR by the OWNER, or may be deducted by OWNER from any monies due or which may become due to the CONTRACTOR pursuant to CONTRACT or otherwise.



**SUPPLY OF CARBON STEEL FLANGES AND FITTINGS
AT COTONOU, BENIN OF WEST AFRICA**



Tender Document No:
A IIP/REPL/011/CSF

Date: 31/03/2023

5. **CONTRACT-CUM-PERFORMANCE BANK GUARANTEE (CPBG): REFER SCC**
6. **SCHEDULE OF RATES:**
 - 6.1 Rates as set forth in the CONTRACT for all SERVICES to be performed and/or GOODS to be delivered shall be on firm price basis and no escalation will be entertained during RATE VALIDITY PERIOD, with the exception of any price variation specified in the CONTRACT.
 - 6.2 The CONTRACTOR is deemed to have satisfied itself as to the circumstances (including risks and contingencies) affecting the price for the provision of the GOODS/SERVICES and/or the cost to the CONTRACTOR of supplying the GOODS/SERVICES and to the correctness and the sufficiency of the rates specified in this CONTRACT for the GOODS/SERVICES which shall, except insofar as it is otherwise provided in this CONTRACT, cover all its obligations under this CONTRACT and all matters and things necessary for the proper supply of the GOODS/SERVICES, whether specifically stated or incorporated by reference to this CONTRACT.
7. **TAXES & DUTIES:**
 - 7.1 The CONTRACTOR shall pay and shall ensure that any of its SUBCONTRACTORS shall pay, all income, corporation, revenue or similar taxes, howsoever described, and all fines, penalties and interest thereon assessed on the income, profits and gains accruing to the CONTRACTOR or any of its SUBCONTRACTORS from the operation of this CONTRACT. The CONTRACTOR shall be responsible for, indemnify, defend and hold harmless the OWNER against any claims whatsoever arising in connection with the liability of the CONTRACTOR or any of its SUBCONTRACTORS for any such taxes, penalties and interest. Further the CONTRACTOR shall be responsible for, indemnify, defend and hold harmless the OWNER against any Claims whatsoever arising in connection with all taxes assessed or levied against or on account of wages, salaries, benefits, or deemed benefits paid to the CONTRACTOR's PERSONNEL.
 - 7.2 The CONTRACTOR shall be required to furnish the OWNER with such particulars as are known to the CONTRACTOR in relation to its or any of its SUBCONTRACTORS activities under this CONTRACT as may be required by the OWNER to fulfil information requests received from any competent tax or GOVERNMENT AUTHORITY. Where requested information is not known to the CONTRACTOR, it shall take reasonable steps to obtain the information necessary to enable it to comply with the request.
 - 7.3 The OWNER may, without liability to the CONTRACTOR, withhold sums in respect of any payments which would otherwise be made by the OWNER to the CONTRACTOR or to any of its SUBCONTRACTORS to the extent that such withholding may be required by legislation or orders, rules or directions of any competent tax authority or GOVERNMENT AUTHORITY. Where the requirement for any withholding is avoided by the CONTRACTOR or any SUBCONTRACTORS holding an appropriate exemption certificate, it is the duty of the CONTRACTOR to inform the OWNER that such a certificate is held and to inform the OWNER of any change to or cancellation of the certificate and to provide copies of the certificate or any further information that may be required by the OWNER to satisfy itself that it can make



**SUPPLY OF CARBON STEEL FLANGES AND FITTINGS
AT COTONOU, BENIN OF WEST AFRICA**



Tender Document No:
A I I P / R E P L / 0 1 1 / C S F

Date: 31/03/2023

payment without any withholding. The CONTRACTOR shall be responsible for, indemnify, defend and hold harmless the OWNER against any Claims whatsoever arising in connection with such withholding or failure to withhold as may arise due to the CONTRACTOR's failure to inform the OWNER of any relevant matter in a timely fashion.

- 7.4 The OWNER shall pay to the CONTRACTOR the applicable direct Tax or any other applicable indirect taxes, howsoever described, levied by any competent GOVERNMENT AUTHORITY, chargeable in respect of SERVICES/GOODS properly supplied by the CONTRACTOR under this CONTRACT, provided that the CONTRACTOR provides the OWNER with a valid tax invoice, as required under the applicable tax law or other legislation, to enable a tax credit to be obtained by the OWNER, wherever applicable. The OWNER shall have no liability to pay the CONTRACTOR for any amount to the extent such amount is eligible for relief, reduction, exemption or recovery by the actions of the CONTRACTOR or any SUBCONTRACTOR.
- 7.5 The CONTRACTOR shall indemnify, defend and hold harmless the OWNER from and against any taxes levied against it on account of any property or equipment (including the CONTRACTOR'S EQUIPMENT) of the CONTRACTOR or any SUBCONTRACTORS including but not limited to local taxes & duties, occupation and other like taxes and imposts.
- 7.6 The CONTRACTOR shall be responsible for, and pay when due, all taxes and duties, as prevailing from time to time, relating to the SERVICES/GOODS supplied. OWNER shall not be responsible for any such liability of the CONTRACTOR. OWNER shall have the right to withhold required amount from payments due to the CONTRACTOR under CONTRACT to the extent that such withholding may be required by the GOVERNMENT or by any GOVERNMENT AUTHORITY, and the payment by OWNER to the respective GOVERNMENT AUTHORITY of the amount of money so withheld shall relieve OWNER from any further obligation to CONTRACTOR with respect to the amount so withheld. The CONTRACTOR undertakes to indemnify OWNER for any loss, outgoing, fine, penalty etc. that CONTRACTOR suffers for tax purposes for the SERVICES/GOODS supplied to OWNER.
- 7.7 CONTRACTOR shall defend, indemnify and hold OWNER harmless from and against any and all claims, expenses and proceedings howsoever arising in connection with the liabilities of CONTRACTOR for any such taxes, fines penalties and interest levied by the GOVERNMENT AUTHORITY or any competent tax authority.
- 7.8 All taxes levied on CONTRACTOR's corporate income or profits shall be for the account of CONTRACTOR and shall not be reimbursed by OWNER.
- 7.9 The OWNER shall also deduct/withhold/charge required amount corresponding to any taxes, prevailing from time to time, levied at the prevailing rates on the Liquidated Damages/ Penalty/ any other such amount deducted/ withheld/ recovered from CONTRACTOR, wherever applicable. OWNER shall have the right to recover/ deduct such amount from CONTRACTOR's invoice, Bank Guarantee or from any outstanding payments due to the CONTRACTOR.
- 7.10 Any statutory variation on account of taxes & duties, as applicable to the SERVICES/GOODS to be supplied under the CONTRACT within the



**SUPPLY OF CARBON STEEL FLANGES AND FITTINGS
AT COTONOU, BENIN OF WEST AFRICA**



Tender Document No:
A IIP/REPL/011/CSF

Date: 31/03/2023

CONTRACT PERIOD, shall be reimbursed by OWNER or refunded by the CONTRACTOR, as the case may be. Such variation shall be limited to direct transactions between the OWNER and the CONTRACTOR, shown as taxes and duties in CONTRACTOR's invoice. However, any additional tax implication, resulting from delay in delivery of SERVICES/GOODS due to reasons not attributable to the OWNER and/or any change in the taxation, registration status of the CONTRACTOR during the CONTRACT PERIOD, shall be borne by the CONTRACTOR.

- 7.11 CONTRACTOR shall, in addition to other taxes, also be responsible for payment of 'CESS' under the Building & Other Workers Welfare Cess Act, 1996, as applicable, and the same will be deposited with relevant authorities with intimation to the OWNER, failing which OWNER will retain the same from running account bill of CONTRACTOR. Said retention amount shall be released upon submission of challan against payment of Cess under the Building & Other Construction Workers Welfare Cess Act, 1996.

8. INVOICING:

- 8.1 Subject to the completion of the CONTRACTOR's obligations in a manner satisfactory to the OWNER in all respects and strictly in accordance with the terms of this CONTRACT, the CONTRACTOR shall submit the invoices to the OWNER for the value ascertained in accordance with the SCHEDULE OF RATES, along with certified measurement sheet or relevant documents as stated by the OWNER REPRESENTATIVE from time to time, for which payment is claimed.
- 8.2 The invoice shall be broken down into individual items in such detail as to enable OWNER to calculate how the total value of the invoice has been reached in accordance to the SOR and shall contain such further information which the OWNER may request. The taxes chargeable in respect of SERVICES/GOODS supplied by the CONTRACTOR under CONTRACT, as applicable, shall be itemized separately.
- 8.3 The CONTRACTOR shall provide proper invoices to OWNER, for the SERVICES/GOODS supplied, containing the below details:
- a) CONTRACT number with description of works
 - b) Service code(s) with description, unit of measurement and quantity delivered
- 8.4 OWNER shall make payment after making deductions, as applicable, but not limited to:
- c) Tax Deduction at Source (TDS)
 - d) Liquidated Damages and/or Penalty charges
 - e) Retention amount
 - f) Any other taxes/statutory deductions as applicable from time to time including applicable taxes levied at prevailing rates on Liquidated Damages / Penalty/ any other such amount deducted/ withheld/ recovered from the CONTRACTOR.
 - g) Any sums owed to the OWNER (as per Clause 7.12) or in case the CONTRACTOR has committed a breach of its obligations under this CONTRACT.

OWNER's decision regarding the above shall be final and binding to the CONTRACTOR.

- 8.5 CONTRACTOR shall submit the invoices immediately upon completion of



**SUPPLY OF CARBON STEEL FLANGES AND FITTINGS
AT COTONOU, BENIN OF WEST AFRICA**



Tender Document No:
A I I P / R E P L / 0 1 1 / C S F

Date: 31/03/2023

the job or as per the agreed periodic billing/invoicing cycle, but not later than 5 days from the date of invoice to avoid non-compliance under Indirect Tax Laws. If any interest, penalties, loss or damage is caused to the OWNER, on account of non-compliance of any existing tax laws due to delayed submission of Invoice by the CONTRACTOR (including but not limited to interest or penalties caused to OWNER on account of delayed payment of tax or loss due to non-availability of any tax credit), such interest, penalties, loss or damage will be recovered from the CONTRACTOR..

- 8.6 Invoices which are incomplete, incorrect or in a form which is unacceptable to the OWNER, shall be returned to CONTRACTOR un-actioned. If the CONTRACTOR submits invoices that contain erroneous billings repetitively in a manner perceived by the OWNER to be excessive, the CONTRACTOR will be assessed a penalty being a percentage of the value of the erroneous invoice, as decided by OWNER.
- 8.7 If the OWNER disputes any item in any invoice, in whole or in part, then the OWNER, at its sole discretion, may pay only the undisputed portion of such invoice, until such time as the OWNER and the CONTRACTOR have reached agreement as to what payment, if any, is due or what other action will be taken by the OWNER in respect of the disputed amount. The OWNER shall promptly notify the CONTRACTOR of any such disputed amount. The OWNER and the CONTRACTOR shall endeavor to settle expeditiously and in good faith, at the earliest possible date, any such dispute and any agreed adjustment and subsequent payment shall be made promptly following the date of such settlement.
- 8.8 The OWNER shall be entitled to set-off against the amounts payable to the CONTRACTOR under this CONTRACT any sums owed to the OWNER by the CONTRACTOR GROUP on any account and howsoever arising.
- 8.9 Unless otherwise specified in the SCC, the OWNER shall pay or cause to be paid the due amount within a period of 30 days from the date of receipt of the complete and correct invoice, duly certified by OWNER'S REPRESENTATIVE as per the terms and conditions of the CONTRACT.
- 9. **DEDUCTIONS FROM THE CONTRACT VALUE:**
 - 9.1 All costs, damages or expenses which OWNER may have paid or incurred, which under the provisions of the CONTRACT fall under the CONTRACTOR's liability, will be claimed by the OWNER. All such claims shall be billed/notified by the OWNER to the CONTRACTOR regularly as and when they fall due. Such claims shall be paid by the CONTRACTOR within 15 (fifteen) days of the receipt of the corresponding intimation from OWNER, and if not paid by the CONTRACTOR within the said period, the OWNER may, then, deduct the amount from any moneys due, such as Contract/ Performance Security, retention money, Bank Guarantee, or payments becoming due to the CONTRACTOR under the CONTRACT or maybe recovered by actions of law or otherwise, if the CONTRACTOR fails to satisfy the OWNER of such claims.
- 10. **PRINTS, DRAWINGS & SPECIFICATIONS (AS APPLICABLE):**
 - 10.1 The CONTRACTOR shall prepare at its own expense and submit to the OWNER such drawings and data as necessary for the performance of this CONTRACT. The OWNER REPRESENTATIVE shall have the right to generally approve all drawings and/or data but such approval or acceptance shall not relieve the CONTRACTOR of any of its responsibilities under this CONTRACT. The CONTRACTOR shall supply, at no extra cost, legible



**SUPPLY OF CARBON STEEL FLANGES AND FITTINGS
AT COTONOU, BENIN OF WEST AFRICA**



Tender Document No:
A IIP/REPL/011/CSF

Date: 31/03/2023

copies of such drawings and data, as applicable.

11. INSPECTION, MONITORING, TESTING AND EXPEDITING:

- 11.1 The OWNER, by its authorized officers and agents, shall at all times be granted access to the CONTRACTOR's premises and/or wherever SERVICES are being performed or any materials, plant and/or equipment are being constructed, manufactured or stored, for expediting, inspecting, monitoring and testing of the SERVICES/GOODS.
- 11.2 Any expediting, monitoring, review, approval, acknowledgement, test or acceptance or waiver thereof by the OWNER shall not relieve the CONTRACTOR from any of its obligations under this CONTRACT in respect of any subsequent defects in the design, quality, materials, workmanship or fitness for purpose of the SERVICES/GOODS.
- 11.3 Wherever applicable, before delivering the GOODS, the CONTRACTOR shall, at no extra cost to the OWNER, unless otherwise specified in the CONTRACT, inspect and test the GOODS for compliance with this CONTRACT and supply to the OWNER legible certificates of the results of such inspection and testing, duly signed & stamped by authorized representative of the CONTRACTOR, as may be reasonably required by the OWNER or required by legislation.
- 11.4 The GOODS may be inspected by the OWNER (i) At OWNER site and/or (ii) At factory premises of the CONTRACTOR/SUBCONTRACTOR or Third party duly approved by the OWNER. The CONTRACTOR shall extend all necessary cooperation to the OWNER / Third Party Inspection agency in carrying out the inspection, as the case may be.
- 11.5 In case if the CONTRACTOR offers the GOODS for inspection and the same fails then third party re-inspection costs as per CONTRACT terms will be borne by the CONTRACTOR, unless explicitly specified otherwise in the CONTRACT.

12. MARKING OF THE GOODS (AS APPLICABLE):

- 12.1 Wherever applicable, the CONTRACTOR shall ensure that the GOODS and, where the components of the GOODS are manufactured by different parties, those components are clearly and permanently marked with the manufacturer's name, trademark or distinguishing mark which clearly identifies the manufacturer. In addition, where the CONTRACTOR is not the manufacturer, the CONTRACTOR shall ensure that the GOODS are, without infringing third parties' rights including IPR, clearly and permanently marked as having been supplied by the CONTRACTOR to the OWNER.
- 12.2 The CONTRACTOR shall ensure that prior to delivery; the GOODS and all components are marked in accordance with the provisions of the CONTRACT. Where the CONTRACT makes no such provision, the GOODS or any components shall not (without the prior written consent of the OWNER) be marked with the name, badge or any other mark used exclusively by the OWNER. Any GOODS or components so marked shall not be disposed off to any third party without the prior written consent of the OWNER unless such markings are first erased to the satisfaction of the OWNER.

13. PACKAGING AND CARRIAGE (AS APPLICABLE):

- 13.1 The GOODS shall be crated, palletted or packed in any such manner so as to reach the DELIVERY POINT undamaged and in good condition.



**SUPPLY OF CARBON STEEL FLANGES AND FITTINGS
AT COTONOU, BENIN OF WEST AFRICA**



Tender Document No:
A IIP/REPL/011/CSF

Date: 31/03/2023

13.2 Unless otherwise stated in this CONTRACT, all costs such as packaging & carriage shall be included in the CONTRACT VALUE. Returnable cases, packages and other containers shall be supplied by the CONTRACTOR free of charge, unless agreed otherwise previously in writing. Where previously requested in writing, such returnable cases, packages and other containers will be returned to the CONTRACTOR but, whilst reasonable care shall be taken to ensure that they are received by the CONTRACTOR in good condition, such return shall be at the CONTRACTOR's risk and expense.

13.3 The CONTRACTOR shall send with each consignment of the GOODS, as applicable:

- a) A packing note (together with a copy of material test certificate(s), where applicable) with the GOODS, detailing the number of this CONTRACT, description, code number (if any) and the quantity of Goods consigned;
- b) An advice note or notes, as instructed in CONTRACT, including details as mentioned in sub-clause a above;
- c) Additional documentation as detailed in the CONTRACT;
- d) The CONTRACTOR's clear and full instructions with regard to all hazards affecting the GOODS; and
- e) Documentation to prove the GOODS supplied have been inspected and, if applicable, are properly completed and therefore fit for purpose.

14. DELIVERY (AS APPLICABLE):

14.1 The CONTRACTOR shall deliver the GOODS to the DELIVERY POINT and as specified in the DELIVERY SCHEDULE.

14.2 Delivery shall be deemed to have been made on acknowledgement of receipt of the GOODS by the OWNER. Delivery of the GOODS to a carrier (whether named by the OWNER or not) for the purpose of transmission to the OWNER is not deemed to be and shall not constitute delivery of the GOODS to the OWNER.

14.3 The OWNER, acting reasonably, may alter the DELIVERY POINT and/or DELIVERY SCHEDULE upon giving the CONTRACTOR reasonable notice in writing of such alterations.

14.4 If the CONTRACTOR fails to deliver any GOODS in accordance with the CONTRACT, then the OWNER may terminate this CONTRACT or any part of it and reserves all rights in damages and otherwise arising.

14.5 If the GOODS are incorrectly delivered, the CONTRACTOR shall be responsible for any additional expense incurred in redelivering such GOODS in the correct manner/to the correct destination and/or at the correct schedule.

14.6 The quantity of GOODS delivered must not exceed the quantity specified in the CONTRACT or intimation by OWNER REPRESENTATIVE. GOODS in excess of the quantity specified shall, at the OWNER's option, be returned to the CONTRACTOR at the CONTRACTOR's expense.

14.7 Acceptance of the GOODS by the OWNER shall not relieve the CONTRACTOR of any of its obligations under this CONTRACT.

15. LIQUIDATED DAMAGES:

15.1 If the CONTRACTOR fails to deliver any or all of the GOODS or perform the



**SUPPLY OF CARBON STEEL FLANGES AND FITTINGS
AT COTONOU, BENIN OF WEST AFRICA**



Tender Document No:
A I I P / R E P L / 0 1 1 / C S F

Date: 31/03/2023

services within the time period(s) specified in the CONTRACT, the OWNER shall, without prejudice to his other remedies under the CONTRACT, deduct from the CONTRACT PRICE, a sum calculated on the basis of the total CONTRACT PRICE, including subsequent modifications.

15.2 In the event the invoice value is not reduced proportionately for the delay, the OWNER may deduct the amount so payable by the CONTRACTOR, from any amount falling due to the CONTRACTOR or by recovery against the Performance Bank Guarantee. Both CONTRACTOR and OWNER agree that the above percentages of price reduction are genuine pre-estimates of the loss/damage which the OWNER would have suffered on account of delay/breach on the part of the CONTRACTOR and the said amount will be payable on demand without there being any proof of the actual loss/or damage caused by such breach/delay. A decision of the OWNER in the matter of applicability of price reduction shall be final and binding.

15.3 The time allowed for carrying out the work as entered in the contract, shall be strictly observed by the contractor. The work shall throughout the stipulated period of the contract be proceeded with all the diligence (time being deemed to be the essence of the Contract) and

(For Services) the contractor shall pay to the Owner as compensation an amount equal to 0.5% of the contract value for every week that the composite work may remain incomplete as per the time schedule, subject to a maximum compensation of 5 % of the total concluded value after which period action will be taken under the provision of the Contract.

(For materials) penalty would be levied @ 1% of total value of the contract per week or part thereof for each extra work taken by the vendor, subject to maximum of 10 % of the total concluded value of contract. In case of delay of more than 10 weeks in supply of material or services beyond a stipulated completion date, SIPI reserves the right to terminate the contract and reserves the right to place order on another vendor.

Any extra expenditure that SIPI will have to incur for procurement of the balance material / services through the other supplier on account of higher rates quoted by the supplier will be recovered from the supplier's retention money, pending bills etc. All lots shall be considered separately for applying PRS in case of delay as described above.

16. FREE ISSUE MATERIAL:

16.1 If, for the purposes of this CONTRACT, materials are to be supplied by or on behalf of the OWNER for incorporation into the GOODS and/or performance of the SERVICES (hereafter referred to as "Free Issue Materials"), they shall be and remain the property of the OWNER, but upon delivery to the CONTRACTOR, become and remain thereafter at the sole risk of the CONTRACTOR, until the delivery of the GOODS and/or performance of the SERVICES, and the return of any surplus Free Issue Materials to the OWNER.

16.2 CONTRACTOR shall clearly identify and mark as "the property of SIPI", separately store, safeguard, maintain in good order and condition and keep such records as the OWNER may require of all Free Issue Materials for audit purpose. All such materials shall be deemed to be in good condition when received by or on behalf of the CONTRACTOR unless it otherwise notifies the OWNER within seven (7) days of receipt.

16.3 CONTRACTOR shall use all Free Issue Materials economically and solely



**SUPPLY OF CARBON STEEL FLANGES AND FITTINGS
AT COTONOU, BENIN OF WEST AFRICA**



Tender Document No:
A IIP/REPL/011/CSF

Date: 31/03/2023

in connection with this CONTRACT. Damage to or loss or waste of any Free Issue Materials arising from bad workmanship, carelessness or the CONTRACTOR's failure to comply with the provisions of sub-clause 15.2 shall be made good at the expense of the CONTRACTOR either by the CONTRACTOR or as the OWNER otherwise instructs, by replacement of materials of at least the equivalent quality.

- 16.4 All scrap and surplus Free Issue Materials are to be marked as "the property of SIPI", kept separately and reported at regular intervals to the OWNER.
- 16.5 OWNER reserves the right to physically inspect/verify the Free Issue Materials at any time. If any loss/shortage/damage is found during such verification by OWNER or in the Free Issue Materials returned by CONTRACTOR, then such lost/short/damaged material cost shall be borne by the CONTRACTOR and necessary amount towards such shortage/damaged material will be recovered from the CONTRACTOR, as per rate decided by OWNER.
- 16.6 Free issue material shall be line pipe of size 12" only. All valves, fittings and line pipe less than 12" etc shall be in CONTRACTOR SCOPE.
17. MATERIAL INSPECTION (AS APPLICABLE):
- 17.1 Upon receipt of GOODS at DELIVERY POINT, OWNER will inspect the packaging for damage or tampering. In case of no damage or tampering of the package, the GOODS will be stored at OWNER's site for further inspection.
- 17.2 OWNER will, at its option, proceed to examine the GOODS to ascertain precise extent of any breakage/ shortage/ tampering/ damage, if any, and in the absence of a representative from CONTRACTOR, the OWNER's report will be deemed accepted by the CONTRACTOR. In case of breakage/ shortage/ tampering/ damage, intimation regarding the same shall be referred to the CONTRACTOR within thirty (30) days from the date of receipt at DELIVERY POINT by the OWNER, which shall be replaced / made good by the CONTRACTOR at their own cost. All risk of loss or damage to the GOODS shall be upon the CONTRACTOR till it is delivered to the OWNER.
- 17.3 If OWNER finds that GOODS supplied are not in accordance to CONTRACT or received in damaged or tampered condition or otherwise not satisfactory owing to any reason, of which the OWNER shall be the sole judge, the OWNER is entitled to take actions such as, but not limited to, rejection of the GOODS, termination of the CONTRACT, procurement of GOODS from other agencies, and recover the loss, if any, from the CONTRACTOR.
- 17.4 The OWNER shall have the right to require the CONTRACTOR at the CONTRACTOR's own risk and expense, expeditiously to collect and replace any rejected GOODS, not later than fifteen (15) days from the date of communication of rejection from OWNER. In case the size of the rejected GOODS or other circumstances make it impracticable for the rejected GOODS, or part thereof, to be removed prior to delivery of the replacement GOODS, the OWNER may require the CONTRACTOR to carry out the necessary replacement at site at the CONTRACTOR's expense.
- 17.5 If the CONTRACTOR fails to fulfill its obligations under this clause within thirty (30) days from the date of intimation of rejection; the OWNER may:
- Dispose the material to any party and expenses, if any, incurred for such disposal, shall be payable by the CONTRACTOR; and/or
 - Terminate this CONTRACT, or any part thereof, in accordance with



**SUPPLY OF CARBON STEEL FLANGES AND FITTINGS
AT COTONOU, BENIN OF WEST AFRICA**



Tender Document No:
A I I P / R E P L / 0 1 1 / C S F

Date: 31/03/2023

Clause 42 of GCC, and/or debar the CONTRACTOR in accordance with Clause 43 of GCC for future tendering/award of contract, without prejudice to its existing rights and remedies; and/or

- c) Recover as a debt due from the CONTRACTOR, all extra costs and expenses arising from or in connection with any GOODS being found to be defective, including but not limited to, those of employing others, repairing, modifying or testing defective GOODS, purchasing alternative GOODS elsewhere and storage, as appropriate.

17.6 Where the CONTRACTOR replaces any GOODS in accordance with this Clause, the provisions of this CONTRACT shall apply to the replacement GOODS.

18. RIGHT TO GET GOODS/SERVICES THROUGH OTHER AGENCIES:

18.1 Nothing contained herein shall restrict OWNER from accepting similar GOODS/SERVICES from other agencies at its sole discretion, if the CONTRACTOR fails to fulfil any of its obligations under the CONTRACT.

18.2 In such event, the OWNER, at its sole discretion, shall be entitled to recover the additional expenses incurred for procuring the GOODS/SERVICES from alternate agencies, in addition to administrative and other expenses incurred by OWNER for the same. The decision of OWNER in determining such amount to be recovered from the CONTRACTOR shall be final and binding on the CONTRACTOR. The CONTRACTOR's liability in this respect shall be unlimited without exception.

19. WARRANTY/ DEFECT LIABILITY:

Successful bidder shall guarantee that material supplied under this PO is new and free from defects. Comprehensive on – site warranty of the Material including parts for both national and international components for 12 months from the date of commissioning or 18 months from the date of Complete receipt of goods at SIPI Stores whichever is earlier, shall be provided by the successful bidder after issue of Purchase Orders. In case onsite warranty is not being provided, the vendor should arrange pick up and drop services at places where the vendor's authorized service centers are present. A list of such service centers should be provided state wise. The response and resolution time during warranty period shall not exceed 48 hours. Intervening holidays would not be counted.

20. AMENDMENT(S):

20.1 BUYER may, by written notice to SELLER, order extra quantity or make changes by altering, adding to or deducting from the GOODS, by way of an AMENDMENT, with no other variation in the unit rates, terms & conditions of the CONTRACT, except as explicitly specified in the AMENDMENT.

20.2 Any modifications leading to changes in the CONTRACT with respect to technical and/or commercial aspects shall be considered valid only when accepted or issued in writing by BUYER. Any other cases shall not be any ground for extension of agreed DELIVERY SCHEDULE and also shall not affect the SELLER's obligations under the CONTRACT in any manner, except to the extent mutually agreed through an AMENDMENT.

20.3 SELLER shall not commence to carry out any AMENDMENT nor shall any claim be valid in respect thereof, until the SELLER has received the formal AMENDMENT issued by BUYER in writing for carrying out such AMENDMENT.



**SUPPLY OF CARBON STEEL FLANGES AND FITTINGS
AT COTONOU, BENIN OF WEST AFRICA**



Tender Document No:
A I I P / R E P L / 0 1 1 / C S F

Date: 31/03/2023

21. PROPERTY & RISK:

- 21.1 Without prejudice to the rights and obligations of the PARTIES under this CONTRACT and unless otherwise agreed in writing, the property in the GOODS or any part thereof shall pass to the OWNER on delivery or on payment by the OWNER (whichever is earlier). In the event of part payments prior to delivery, property in the GOODS shall pass in proportion to payments made. Notwithstanding passing of property to the OWNER risk shall not pass to the OWNER until all of the GOODS have been delivered in accordance with this CONTRACT at the DELIVERY POINT.
- 21.2 Where the property in any of the GOODS passes to the OWNER before delivery, such GOODS shall be stored separately, clearly identified and marked as "the property of SIPI" or in such other manner as the OWNER may require.
- 21.3 Unless otherwise agreed in writing, all tools, patterns, drawings, designs, other documents, equipment or materials supplied by or on behalf of the OWNER shall be stored separately, marked as "the property of SIPI" and remain the property of the OWNER and the CONTRACTOR shall be responsible for their safe custody and return. They shall not, without the prior written consent of the OWNER, be disposed of by the CONTRACTOR to any third party nor used except for the purpose of carrying out this CONTRACT.

22. SUB-LETTING OF CONTRACT:

- 22.1 No part of this CONTRACT, nor any share or interest therein, in any manner or extent, will be transferred or assigned or sub-let, directly or indirectly, to any person / firm or organization by the CONTRACTOR without written consent of the OWNER, provided nevertheless that any such consent shall not relieve the CONTRACTOR from any obligation, duty or responsibility under the CONTRACT.

23. ASSIGNMENT:

- 23.1 The CONTRACT shall be binding on and ensure to the benefit of OWNER and CONTRACTOR and to their respective heirs, executors, administrators, successors and assigns, but the CONTRACTOR shall not assign this CONTRACT in whole or in part or any benefit of any legal or equitable interest herein without the prior written consent of the OWNER.
- 23.2 The OWNER shall be permitted to assign and re-assign (whether on one or several occasions) all or any of the provisions of this CONTRACT to any of its Affiliates and/or Group Companies by giving advance intimation to the CONTRACTOR.
- 23.3 The CONTRACTOR shall be responsible for acts, omissions and defaults of any of its representatives including its agents as fully as if they were the acts, omissions and defaults of the CONTRACTOR and any assignment shall not relieve the CONTRACTOR of any of its responsibilities under this CONTRACT or at Law.

24. NON-WAIVER:

- 24.1 No relaxation, forbearance, delay or indulgence by either party (CONTRACTOR or OWNER) in enforcing any of the terms and conditions of the CONTRACT or the granting of time by either party to the other shall prejudice, affect or restrict the rights of that party under the CONTRACT, nor shall any waiver by either party of any breach of CONTRACT operate as a waiver of any subsequent or continuing breach of CONTRACT.



**SUPPLY OF CARBON STEEL FLANGES AND FITTINGS
AT COTONOU, BENIN OF WEST AFRICA**



Tender Document No:
A I I P / R E P L / 0 1 1 / C S F

Date: 31/03/2023

24.2 Any waiver of a party's rights, powers or remedies under the CONTRACT must be in writing, must be dated and signed by an authorized representative of the party granting such waiver, and must specify the right and the extent to which it is being waived.

25. SEVERABILITY

25.1 If any provision or condition of the CONTRACT is prohibited or rendered invalid or unenforceable, such prohibition, invalidity or unenforceability shall not affect the validity or enforceability of any other provisions and conditions of the CONTRACT.

26. SAVING OF RIGHTS:

26.1 The expiry or earlier termination of the CONTRACT, howsoever occasioned, shall be without prejudice to the rights and remedies of the Parties to the CONTRACT up to and including the date of such expiry or earlier termination, and shall not affect or prejudice any term of CONTRACT that is expressly or by implication provided to come into effect on or continue in effect after such expiry or earlier termination.

27. STATUS OF OWNER AND THE CONTRACTOR:

27.1 In performing its obligations under this CONTRACT, the CONTRACTOR shall maintain complete employer control over the CONTRACTOR's PERSONNEL. This CONTRACT constitutes a principal-to-principal relationship between the CONTRACTOR and the OWNER and does not and shall in no manner create or be construed to create any employment, agency, partnership, joint venture or any other relationship between the PARTIES hereto.

27.2 The CONTRACTOR shall, as between the CONTRACTOR and the OWNER, be responsible for and shall be liable for, indemnify, defend and hold harmless the OWNER against all wages, fees, contributions, insurances, charges and taxes required by Law to be paid by an employer in respect of the CONTRACTOR's PERSONNEL and/or the supply of the GOODS/SERVICES and shall procure that all appropriate deductions are made in respect of all applicable taxes and other contributions.

28. CHANGE IN CONSTITUTION:

28.1 Where the CONTRACTOR is a partnership firm, the prior approval of the OWNER shall be obtained in writing, before any change is made in the constitution of the firm.

28.2 Where the CONTRACTOR is an individual, such approval as aforesaid shall, likewise be obtained before such CONTRACTOR enters into any agreement with other parties, where under the reconstituted firm would have the right to carry out the work hereby undertaken by the CONTRACTOR.

28.3 In either case if prior approval as aforesaid is not obtained; the CONTRACT shall be voidable at the option of the OWNER. The OWNER shall be entitled to terminate the CONTRACT in accordance with Clause 42 of GCC.

29. REPRESENTATIVES:

29.1 OWNER's REPRESENTATIVE shall communicate to CONTRACTOR all information, instructions and decisions of OWNER. All information, instructions and Decisions issued by OWNER's REPRESENTATIVE shall be deemed to have been issued by OWNER.

29.2 OWNER's REPRESENTATIVE may, from time to time, delegate any



**SUPPLY OF CARBON STEEL FLANGES AND FITTINGS
AT COTONOU, BENIN OF WEST AFRICA**



Tender Document No:
A I I P / R E P L / 0 1 1 / C S F

Date: 31/03/2023

responsibilities to any nominated deputy and withdraw any such delegation. The terms of such delegation shall be the subject of a notice, issued in accordance with Clause 29 of GCC. Information, instructions and decisions issued by any nominated deputy, acting within the terms of his delegated authority, shall be as if issued by OWNER's Representative.

29.3 CONTRACTOR's Representative shall be authorized to act on behalf of CONTRACTOR in all Matters relating to the CONTRACT and any written order, instruction or Notice from OWNER to CONTRACTOR's Representative or CONTRACTOR's Personnel shall be deemed to have been given to CONTRACTOR.

30. NOTICES:

30.1 Any Notices shall be in writing and will take effect from the date of receipt at the communication address. Suitable proof of delivery like speed post acknowledgment receipt, registered AD acknowledgment receipt, hand-delivered acknowledgment & electronic mail are acceptable modes of acknowledgment.

30.2 In case of speed post and registered AD notices, a copy of Notice is required to be sent for acknowledgment of contents and acknowledgment on this copy of Notice by OWNER which will be returned to CONTRACTOR & shall be considered as valid acknowledgment of Notice.

30.3 All Notices shall be sent to respective representatives of PARTIES.

31. CLAIMS:

31.1 The CONTRACTOR shall protect and hold the GOODS and all property of the OWNER Group free from all liens, charges and other encumbrances.

31.2 Upon receipt of a Notice from the OWNER, the CONTRACTOR shall discharge or cause to be discharged all liens, charges or other encumbrances attaching to or upon any materials, goods, equipment, plant or other items provided by the CONTRACTOR Group for use for or in connection with the completion of the Work associated with the GOODS which in the opinion of the OWNER may adversely affect the performance of the CONTRACTOR's obligations under the CONTRACT.

31.3 The CONTRACTOR shall be responsible for, indemnify, defend and hold harmless the OWNER Group against any and all Claims in respect of liens, charges or other encumbrances irrespective of negligence and/or breach of duty (statutory or otherwise) of the OWNER Group.

31.4 The OWNER may discharge any lien, charge or other encumbrance and may deduct from payment due to the CONTRACTOR or recover by other means as a debt due from the CONTRACTOR all costs and expenses reasonably incurred in so doing.

31.5 If, at any time there should be evidence or any lien or claim for which the OWNER might have become liable and which is chargeable to the CONTRACTOR, the OWNER shall have the right to retain out of any payment then due or thereafter to become due an amount sufficient to completely indemnify the OWNER against such lien or claim and if such lien or claim be valid, the OWNER may pay and discharge the same and deduct the amount so paid from any money which may be or may become due and payable to the CONTRACTOR.

31.6 If any lien or claim remain unsettled after all payments are made, the CONTRACTOR shall refund or pay to the OWNER all money that the latter



**SUPPLY OF CARBON STEEL FLANGES AND FITTINGS
AT COTONOU, BENIN OF WEST AFRICA**



Tender Document No:
A I I P / R E P L / 0 1 1 / C S F

Date: 31/03/2023

may be compelled to pay in discharging such lien or claim including all costs and reasonable expenses. OWNER reserves the right to do the same.

32. INSURANCE (AS APPLICABLE):

32.1 CONTRACTOR shall at his own expense arrange secure and maintain insurance as applicable with reputable insurance companies to the satisfaction of the OWNER as follows:

32.2 CONTRACTOR at his cost shall arrange, secure and maintain insurance as may be necessary and to its full value for all such amounts to protect the works in progress from time to time and the interest of OWNER against all risks as detailed herein. The form and the limit of such insurance, as defined here in together with the under works thereof in each case should be as acceptable to the OWNER. However, irrespective of work acceptance the responsibility to maintain adequate insurance coverage at all times during the period of CONTRACT shall be that of CONTRACTOR alone. CONTRACTOR's failure in this regard shall not relieve him of any of his responsibilities and obligations under CONTRACT.

32.3 Any loss or damage to the work/ material, during transportation, storage, erection and completion of work till such time the WORK is taken over by OWNER, shall be to the account of CONTRACTOR. CONTRACTOR shall be responsible for preferring of all claims and make good for the damage or loss by way of repairs and/or replacement of the parts of the Work damaged or lost. CONTRACTOR shall provide the OWNER with a copy of all insurance policies and documents taken out by him in pursuance of the CONTRACT. Such copies of document shall be submitted to the OWNER immediately upon the CONTRACTOR having taken such insurance coverage. CONTRACTOR shall also inform the OWNER at least thirty days in advance regarding the expiry cancellation and/or changes in any of such documents and ensure revalidation/renewal etc., as may be necessary well in time.

32.4 All costs on account of insurance liabilities covered under CONTRACT will be to CONTRACTOR's account and will be included in value of CONTRACT. However, the OWNER may from time to time, during the currency of the CONTRACT, ask the CONTRACTOR in writing to limit the insurance coverage risk and in such a case, the parties to the CONTRACT will agree for a mutual settlement, for reduction in value of CONTRACT to the extent of reduced premium amounts.

33. INDEMNITY:

33.1 To the fullest extent permitted by Law, CONTRACTOR shall indemnify, defend, and hold harmless OWNER, its affiliates, and subsidiary companies or entities, and its and their respective officers, directors, agents, and employees from and against all claims, liabilities, damages, losses, costs, and expenses including, but not limited to, attorneys' fees and costs of court (collectively, the "Claims"), arising out of, connected with, or alleged to arise from or be connected with any event or circumstance which occurs or exists, or is alleged to have occurred or existed, in any way related to the manufacture, delivery, performance or installation of the GOODS/SERVICES, either directly or indirectly, including (without limiting the generality of the foregoing) all Claims on account of personal injury, death, or property loss to CONTRACTOR, OWNER, or any other party, including any Claims based upon or arising out of CONTRACTOR's sole, joint, or contributory negligence or strict liability, except to the extent that any such Claim arises out of, or is attributable, to OWNER's gross

negligence or wilful misconduct.

33.2 The CONTRACTOR shall at all times indemnify and keep indemnified OWNER against all CLAIMS, loss, demands, proceedings, charges and expenses, liability of personal injury (including death), and/or damage omission or default by the CONTRACTOR or his representative and arising out of or connected with the performance of CONTRACT and arising out of non-compliance with the Law.

33.3 The CONTRACTOR undertakes responsibility for and shall indemnify OWNER or their employees from all liability, CLAIMS, costs, expenses, taxes and assessments including penalties, punitive damages, attorney's fees and court cost with respect to any breach of the CONTRACTOR's obligation under the CONTRACT or for which the CONTRACTOR has assumed under any order local or national Law or Laws.

34. EMPLOYMENT LIABILITY OF CONTRACTOR:

34.1 The CONTRACTOR shall indemnify OWNER & shall be solely and exclusively responsible for any liability arising due to any difference or dispute between him and his employee / Third Party for the execution of this contract at any time during / after the contract period is over. All workmen engaged by the CONTRACTOR shall preferably be on his roll and be paid by him and OWNER shall have no responsibility towards them.

34.2 The CONTRACTOR shall be directly responsible and indemnify the OWNER against all charges, claims, dues, etc. arising out of disputes relating to the dues and employment of personnel deployed by him.

34.3 The CONTRACTOR shall indemnify the OWNER against all losses or damages caused to it on account of acts of the personnel deployed by the CONTRACTOR.

34.4 The CONTRACTOR shall ensure regular and effective supervision of the personnel deployed by him. All liability arising out of accident and death while on duty shall be borne by CONTRACTOR.

35. CONSEQUENTIAL & INDIRECT DAMAGES:

35.1 Notwithstanding anything contained elsewhere in this CONTRACT neither party shall be liable for whether in contract, tort, or otherwise, for any indirect or consequential loss or damage, loss of use, loss of production, or loss of profits or interest costs.

36. LIMITATION OF LIABILITY:

36.1 Notwithstanding anything contrary contained herein, the aggregate total liability of the CONTRACTOR under the CONTRACT or otherwise shall be limited to 100% of the CONTRACT VALUE. However, the aforesaid cap for limitation of liability shall not apply and the CONTRACTOR shall continue to remain responsible for all liabilities which arise on account of:

- a) Breach of Applicable Laws by the CONTRACTOR
- b) Gross negligence, fraud, or wilful misconduct of the CONTRACTOR.
- c) Infringement of any Intellectual Property Rights of the OWNER.
- d) Indemnification of OWNER as per Clause 32 of GCC and as specified elsewhere in the CONTRACT.
- e) Provisions under Clause 17.2 of GCC



**SUPPLY OF CARBON STEEL FLANGES AND FITTINGS
AT COTONOU, BENIN OF WEST AFRICA**



Tender Document No:
A IIP/REPL/011/CSF

Date: 31/03/2023

37. CONFIDENTIALITY:

37.1 The CONTRACTOR and/or the CONTRACTOR's PERSONNEL shall not, during the continuance of this CONTRACT, or at any time thereafter, publish or disclose to any third party, except with the written consent of the OWNER or by requirement of the Legislation, any information, data or process which is confidential or of a commercially sensitive nature connected with the business or affairs of the OWNER which shall come or have come to its or their knowledge in or by reason of the engagement by the OWNER of the CONTRACTOR under this CONTRACT, provided that this restriction shall not apply to any information:

However, these obligations do not apply to documents for which it can be demonstrated that:

- a) Such documents were already in the public domain before these were communicated to the other PARTY, or have become part of the public domain since without any fault or negligence of the PARTY concerned, or
- b) Such documents were already in its possession without having obtained them directly or indirectly from the other PARTY, or
- c) Such documents were obtained from an independent source that had neither direct nor indirect secrecy commitment to the other PARTY.

37.2 The experts appointed by the OWNER are not considered as third parties, and for this reason they have to respect, towards the CONTRACTOR, the same obligations as the OWNER in these matters.

37.3 Any document, other than the Agreement itself, enumerated shall remain the property of the OWNER and shall be returned (all copies) to the OWNER on completion of the CONTRACTOR's obligations under the Agreement, if so required by the OWNER.

38. PUBLICATION AND PRESS ANNOUNCEMENTS:

38.1 CONTRACTOR, either alone or jointly with others, cannot publish material or make press releases or announcements regarding either this CONTRACT or the activities of the CONTRACTOR related to its participation in this CONTRACT. Such publication shall be subject to prior approval of the OWNER in writing.

39. INTELLECTUAL PROPERTY RIGHTS (IPR) AND TRADEMARKS:

39.1 All intellectual property Rights or IPR in all documents including (without limitation) drawings, transparencies, prints, photographs, negatives, computer files, working notes and books created, supplied or developed by the OWNER and appertaining to the GOODS shall remain in the OWNER and the originals and all copies of them shall be delivered to the OWNER on completion of the work associated with the GOODS and the CONTRACTOR and any SUBCONTRACTORS shall, if required, certify that none have been retained.

39.2 All documents, drawings, technical know-how, calculations, computer print-outs, computer files, computer software designs and inventions created, supplied or developed by the CONTRACTOR pursuant to or in the performance of this CONTRACT whether fully or partially completed and relating to the GOODS shall be the property of the OWNER and the copyright for the same shall be vested in the OWNER.

39.3 Subject to the OWNER's rights pursuant to this CONTRACT, the



**SUPPLY OF CARBON STEEL FLANGES AND FITTINGS
AT COTONOU, BENIN OF WEST AFRICA**



Tender Document No:
A IIP/REPL/011/CSF

Date: 31/03/2023

CONTRACTOR shall retain all intellectual property in all documents including (without limitation) drawings, transparencies, prints, photographs, negatives, computer files, working notes and books and inventions created by the CONTRACTOR prior to this CONTRACT and which shall not have been prepared by the CONTRACTOR at the request of the OWNER or pursuant to a previous contract or arrangement with the OWNER.

- 39.4 The CONTRACTOR shall be responsible for, indemnify, defend and hold harmless the OWNER from and against any and all Claims which arise out of, or in any way relate to, any patent, registered design, copyright, trademark or trade name or any patent application or other proprietary right asserted by the CONTRACTOR and SUBCONTRACTOR, any employee of either of the foregoing or any third party in respect of any device, apparatus, process or method used by the CONTRACTOR in performing its obligations under the CONTRACT.
- 39.5 Should the CONTRACTOR or any SUBCONTRACTOR infringe, or allegedly infringe, any patent, registered design, copyright, trademark or trade name which delays or prevents the CONTRACTOR from carrying out its obligations under this CONTRACT, the OWNER may treat such cessation or delay to the completion of the work associated with the GOODS arising there from as a fundamental breach of this CONTRACT by the CONTRACTOR. The CONTRACTOR shall be liable for all additional costs incurred by the OWNER pursuant to its mitigation of the effects of such cessation or delay.
- 39.6 The CONTRACTOR shall promptly disclose to the OWNER all inventions which it or any SUBCONTRACTOR may make which are wholly or in part based on or derived from information arising from the completion of the GOODS. All rights, titles and interest in and to such inventions shall belong to the OWNER. The CONTRACTOR shall execute or have executed all documents and shall perform or have performed all such acts as the OWNER may deem desirable or necessary to protect the OWNER's title to such inventions and to obtain and maintain patent coverage therein throughout the world.
- 39.7 Nothing in this contract confers upon the CONTRACTOR any right to use trademarks, trade names or service marks or even otherwise, nor shall any CONTRACTOR adopt any trademark which is confusingly similar to any a trademark of the OWNER.
- 40. PERMITS, LICENSES, STATUTORY AND OTHER REQUIREMENTS:**
- 40.1 The CONTRACTOR shall obtain at its own risk and expense, all permits, licenses, registrations, certificates or other administrative authorizations as may be required by any GOVERNMENTAL AUTHORITY from time to time or may be necessary or incident to the CONTRACTOR's business in the jurisdictions where the CONTRACTOR has to fulfil its obligations under this CONTRACT.
- 40.2 The CONTRACTOR shall comply with the Legislation and other requirements affecting the completion of the work associated with the GOODS/SERVICES, including delivery as per the CONTRACT.
- 40.3 The CONTRACTOR shall not under any circumstances apply to, or enter into negotiations with, or agree with any GOVERNMENTAL AUTHORITY or agency for acceptance of variations from or revisions to Legislation without the OWNER's prior written consent, except to the extent such matters pertain only to the CONTRACTOR's equipment and the CONTRACTOR's



**SUPPLY OF CARBON STEEL FLANGES AND FITTINGS
AT COTONOU, BENIN OF WEST AFRICA**



Tender Document No:
A I I P / R E P L / 0 1 1 / C S F

Date: 31/03/2023

PERSONNEL, which do not and cannot directly or indirectly affect the OWNER's legal obligations, equipment, sites or personnel.

41. FORCE MAJEURE:

41.1 Neither PARTY shall be responsible for any loss or damage of any kind caused by a failure or delay in performance of any obligation hereunder if such failure or delay is attributable to FORCE MAJEURE.

41.2 For the purposes of CONTRACT only the following occurrences shall be deemed to constitute FORCE MAJEURE:

- a) Riot, war, invasion, act of foreign enemies, hostilities (whether war be declared or not), act of terrorism, civil war, rebellion, revolution, insurrection of military or usurped power;
- b) Earthquake, flood, drought, earthquake, cyclone, fire, explosion and/or other natural physical disaster, but excluding weather conditions as such, regardless of severity;
- c) Changes to any general or local statute, ordinance, decree, or other LAW, or any regulation or bye-law of any local or other duly constituted authorized or the introduction of any such statute, ordinance, decree, law, regulation or bye-law.

41.3 The CONTRACTOR shall not under any circumstances be relieved or excused from its obligation to perform to the extent that the cause of such failure or delay in performance is caused by:

- a) Unfavorable weather conditions which are reasonably expected for the climate in the geographic area where the work is to be performed; or
- b) any delay, default or failure (direct or indirect) by the CONTRACTOR in obtaining materials, equipment or manpower required for performing any work; or
- c) financial distress of the CONTRACTOR; or
- d) strikes, disputes or other action solely among employees of CONTRACTOR or its sub-CONTRACTORS or CONTRACTOR/sub-CONTRACTOR of the CONTRACTOR; or
- e) Mechanical breakdown.
- f) Shortage of labour, materials or other resources unless caused by circumstances which are themselves force majeure in nature.

41.4 A PARTY, which is, by reason of FORCE MAJEURE, unable to perform any obligation or condition required by this CONTRACT to be performed shall notify the other PARTY in writing within 24 hours, giving reasonably full particulars of the event or circumstance of FORCE MAJEURE, from the date of commencement of the event or circumstance and an estimate of the period of time required to enable it to resume full performance of its obligations.

41.5 The obligations of the PARTIES under this contract to the extent performance thereof is prevented by the event of FORCE MAJEURE shall be suspended and the PARTIES shall not be liable for the non-performance thereof for the duration of the period of FORCE MAJEURE.

41.6 If performance of the CONTRACTOR is suspended by FORCE MAJEURE conditions for a period of 2 (two) weeks or more, then OWNER may in its sole discretion terminate this CONTRACT with immediate effect either in



**SUPPLY OF CARBON STEEL FLANGES AND FITTINGS
AT COTONOU, BENIN OF WEST AFRICA**



Tender Document No:
A IIP/REPL/011/CSF

Date: 31/03/2023

whole or in part at any time thereafter by giving notice thereto.

42. SUSPENSION OF CONTRACT:

42.1 The CONTRACTOR shall, if instructed in writing by the OWNER'S REPRESENTATIVE, temporarily suspend the works/SERVICES or any part thereof for such written instruction, and resume the same only after receipt of written intimation to proceed therewith.

42.2 The CONTRACTOR shall not be entitled to claim compensation for any loss or damage sustained by reason of temporary suspension of the works/SERVICES aforesaid. An extension of time for completion, corresponding with the delay caused by any such suspension as aforesaid will be granted to the CONTRACTOR, should he apply for the same, provided that the suspension was not consequent to any default or failure on the part of the CONTRACTOR.

43. TERMINATION AND EFFECT OF TERMINATION:

43.1 The OWNER reserves the right to terminate the contract either in whole or in part, upon occurrence of one or more of the following events by giving 30 days' notice in writing to the CONTRACTOR:

- a) Breach of contractual obligation by the CONTRACTOR
- b) Insolvency or bankruptcy of the CONTRACTOR, or being a OWNER, entering into receivership, administrative receivership, administration or liquidation (or any equivalent thereof) whether compulsory or voluntary, except liquidation for the purpose of reconstruction or amalgamation while solvent.
- c) Failure to fulfil any of the CONTRACTOR's obligations under the CONTRACT

The decision of the OWNER regarding occurrence of any of the aforesaid events shall be final and binding on the PARTIES.

43.2 Without prejudice to, and in addition to, the OWNER's other rights under this CONTRACT; the OWNER shall have the right to terminate this CONTRACT or any part thereof without assigning any reason at any time by giving 24 hours written notice to the CONTRACTOR.

43.3 In the event the OWNER terminates the CONTRACT in whole or in part, as above, the OWNER may procure, upon such terms and in such manner as it deems appropriate, goods /services similar to those undelivered and the CONTRACTOR shall be liable to the OWNER for any excess costs for such similar goods/ services. However, the CONTRACTOR shall continue performance of the CONTRACT to the extent not terminated. This is without prejudice to any of the OWNER's rights to deduct/ withhold any amount as specified elsewhere in this CONTRACT.

43.4 If GOODS procured by the CONTRACTOR, but not utilized till date of termination will be the responsibility of the CONTRACTOR and no claim will be entertained by the OWNER for the same.

43.5 The CONTRACTOR shall be responsible for, indemnify, defend and hold harmless the OWNER against any costs incurred by the CONTRACTOR including, but not limited to, input material/labour cost, etc. In case OWNER has to incur expenses due to the same, the same shall be recovered from the dues payable to the CONTRACTOR and / or security deposit held with OWNER.



**SUPPLY OF CARBON STEEL FLANGES AND FITTINGS
AT COTONOU, BENIN OF WEST AFRICA**



Tender Document No:
A IIP/REPL/011/CSF

Date: 31/03/2023

43.6 GOODS shall not be or be deemed to be an asset in a bankruptcy if CONTRACTOR, voluntarily or not, becomes or is declared bankrupt.

44. DEBARMENT OR SUSPENSION:

44.1 OWNER reserves the right of Debarment or Suspension for the CONTRACTOR, upon occurrence of one or more of the following events by giving written intimation to the CONTRACTOR:

a) In case of any conviction for criminal offence pertaining to the CONTRACTOR or its director or subcontract, or indicating a lack of business integrity or honesty which directly and seriously affects the business of the OWNER; or

b) In case of any serious breach of the CONTRACT indicating an unwillingness or inability to perform the CONTRACT in accordance with the terms and conditions or in accordance with the specifications, or a record of unsatisfactory performance of this CONTRACT or one or more related CONTRACTs in accordance with the terms and conditions thereof, or in accordance with its specifications; or

c) The breach of any ethical standard set out by the OWNER

44.2 The decision of OWNER regarding Debarment or Suspension and/or occurrence of any of the aforesaid events or Debarment for future tendering / award of any contract shall be final and binding on the PARTIES.

44.3 The Suspension or Debarment shall take effect immediately upon receipt of written intimation to the CONTRACTOR.

45. GOVERNING LAW AND ARBITRATION:

45.1 The PURCHASER and the SELLER shall make every effort to resolve amicably by direct informal negotiations any disagreement or dispute arising between them under or in connection with the contract.

45.2 If, after thirty days from the commencement of such informal negotiations, the PURCHASER and the SELLER have been unable to resolve amicably a Contract dispute, either party may require that the dispute be referred for resolution to the formal mechanism as specified here under.

45.3 Legal Construction

The Contract shall be, in all respects be construed and operated as an Benin Contract and in accordance with Republic of Benin Laws as in force for the time being and is subject to and referred to the Court of Law situated within Republic of Benin, West Africa.

45.4 Arbitration

All disputes, controversies, or claims between the parties (except in matters where the decision of the Engineer-in-Charge is deemed to be final and binding) which cannot be mutually resolved within a reasonable time shall be referred to Arbitration by a sole arbitrator. The PURCHASER shall suggest a panel of three independent and distinguished persons to the Seller to select any one among them to act as the sole Arbitrator.

In the event of failure of the Seller to select the Sole Arbitrator within 30 days from the receipt of the communication suggesting the panel of arbitrators, the right of selection of Sole Arbitrator by the other party shall stand forfeited and the PURCHASER shall have discretion to proceed with the appointment of the Sole Arbitrator. The decision of the PURCHASER on the appointment of Sole Arbitrator shall be final and binding on the



**SUPPLY OF CARBON STEEL FLANGES AND FITTINGS
AT COTONOU, BENIN OF WEST AFRICA**



Tender Document No:
A I I P / R E P L / 0 1 1 / C S F

Date: 31/03/2023

parties.

The award of the Sole Arbitrator shall be final and binding on the parties and unless directed/awarded otherwise by the Sole Arbitrator, the cost of arbitration proceedings shall be shared equally by the parties. The arbitration proceeding shall be in English language and the venue shall be at Republic of Benin, West Africa.

All matters relating to this contract are subject to the exclusive jurisdiction of the Courts situated in the Republic of Benin, West Africa.

The WORK under the CONTRACT shall, however, continue during the Arbitration proceedings and no payment due or payable to the Seller shall be withheld on account of such proceedings.

46. COMPLIANCE WITH LEGAL REQUIREMENTS:

46.1 The Agency shall comply with all legal requirements under various applicable laws.

46.2 In the event, SIPI is required to pay any compensation or any other amount to any employee / representative of the Agency, the Agency hereby unconditionally agrees to indemnify SIPI against any such loss / liability.

46.3 Contractor hereby agrees and undertakes to comply with all applicable legal requirements and follow standard construction practices and agrees to indemnify SIPI in the event of failure of contract or to comply with any legal requirement and / or follow best construction practices prevailing in the industry.

47. CONFLICT OF INTEREST, ETHICAL STANDARDS:

47.1 The CONTRACTOR shall not, without the prior approval of the OWNER, participate in any business entity where use could be made of, or divulge to any third party, any information, knowledge or a relationship arising out of the CONTRACT or where such participation or action could conflict with the interests of OWNER.

47.2 No director, officer, employee, consultant or servant of the CONTRACTOR shall enter into any business arrangement with any director, officer, employee, consultant or servant of OWNER without full written and timely disclosure to OWNER.

47.3 The CONTRACTOR shall not accept any commission or any other payment from tenderers, contractors, vendors or any third party concerned with the work.

47.4 Each PARTY represents and warrants that it has conducted and shall conduct its business in accordance with the highest ethical standards and it shall comply with all applicable Laws in the performance of its obligations under the CONTRACT including but not limited to Laws dealing with ethical business practices. If at any time during the term of the CONTRACT a party hereto is informed or information comes to such Party's attention that it is or may be in violation of any applicable Law (or if it is so determined by any court, tribunal or other governmental authority), such Party shall immediately take all appropriate steps to remedy such violation and comply with such Law in all respects. Further, each Party hereto shall establish and maintain all proper records (including accounting records) required by applicable Law.

48. CORRUPT AND FRAUDULENT PRACTICES:

48.1 The OWNER requires that CONTRACTOR observe the highest standard of ethics during the execution of CONTRACT. In pursuance of this policy, the OWNER defines, for the purposes of this provision, the terms set forth below as follows:

- a) "Corrupt Practice" means the offering, giving, receiving, or soliciting of anything of value to influence the action of public official in contract execution; and
- b) "Fraudulent Practice" means a misrepresentation of facts in order to influence the execution of a CONTRACT to the detriment of the OWNER, and includes collusive practice amongst CONTRACTORS (prior to or after bid submission) designed to establish bid prices at artificial non-competitive levels and to deprive the OWNER of the benefits of free and open competition;
- c) "Unfair trade practices" means supply of materials different from what is ordered on, or change in the Scope of Work which was given by OWNER in the CONTRACT
- d) "Coercive Practices" means harming or threatening to harm, directly or indirectly, persons or their property to influence their participation in the execution of Contract.

48.2 OWNER will reject a proposal for award, if it determines that the CONTRACTOR recommended for award is engaged in Corrupt or Fraudulent or Unfair trade or Coercive Practices in competing for the award in question;

48.3 OWNER will declare a firm ineligible, either indefinitely or for a stated period of time, if at anytime the OWNER determines that the firm has engaged in Corrupt or Fraudulent or Unfair trade or Coercive Practices in competing for or in executing a contract.

49. AGENTS AND INTERMEDIARIES

49.1 CONTRACTOR represents warrants and undertakes to CONTRACTOR that it and each of its Affiliates and their respective officers, directors, employees or other representatives have not:

- a) used, and will not use, the services of an agent or intermediary; or
- b) made or offered to make, and will not make any payment or transfer of anything of value directly or indirectly to any agent or intermediary or to any CONTRACTOR Personnel, in connection with CONTRACTOR's prequalification/short listing for, or the award of, the CONTRACT or in connection with any variation subsequently agreed under the CONTRACT.

49.2 Any breach of this provision shall be a material breach of the CONTRACT entitling OWNER to terminate the CONTRACT.

50. POSSESSION PRIOR TO COMPLETION

50.1 The OWNER'S REPRESENTATIVE shall have the right to take possession of or use any completed or partially completed work/SERVICES or part of the work/SERVICES. Such possession or use shall not be deemed to be an acceptance of any work/SERVICES completed in accordance with the CONTRACT.

50.2 If such prior possession or use by the OWNER'S REPRESENTATIVE



**SUPPLY OF CARBON STEEL FLANGES AND FITTINGS
AT COTONOU, BENIN OF WEST AFRICA**



Tender Document No:
A I I P / R E P L / 0 1 1 / C S F

Date: 31/03/2023

delays the progress of work/SERVICES, equitable adjustment in the time of completion will be made and the CONTRACT shall be amended accordingly in writing by the OWNER.

51. COMPLIANCE OF INTERNATIONAL LABOUR STANDARD:

CONTRACTOR shall be solely responsible for strictly following all Labour Laws, Industrial Laws, which are applicable from time to time including, but not limited to, the notification amendments or additions which are made to these laws during the period of CONTRACT. The CONTRACTOR shall have to, at his own expenses, comply with labour laws and keep the company indemnified in respect thereof. Some of the major liabilities under various labour and industrial laws which the CONTRACTOR shall comply with are as under, but not limited to:

- 51.1 CONTRACTOR, before actual deployment of Contract Labour, shall obtain necessary license from appropriate licensing authority as per prevailing rules & regulation and as modified from time to time during contract period.
- 51.2 CONTRACTOR shall ensure regular & effective supervision of the personnel deployed by him and to ensure safety & security of his personnel. The Contractor shall issue an Identity card with photograph to all his personnel under applicable statute/Act. The identity card should be displayed while at work & to be produced as & when asked by the authorized officer of the Company.
- 51.3 CONTRACTOR shall be solely liable to obtain & keep valid and a subsisting license during the period of contract under ILO of OHS and all necessary licenses from competent authority as provided under various labour laws & bear all such costs related to adhering to all such applicable laws including payment of any applicable taxes and duties prescribed in the relevant laws. The CONTRACTOR shall not claim any non-adherence or default due to lack of information as to applicability of any law and shall be solely responsible for the same. Further the CONTRACTOR shall keep the OWNER indemnified and harmless from any liability, penalty which might be imposed including any cost, expenses which OWNER might be required to bear/incur by reason of any asserted or established violation of such laws, regulations, ordinances or other rules.
- 51.4 CONTRACTOR shall not engage / deploy any person who has not completed the age of 18 years under this contract, and the person(s) to be deployed should be physically and mentally fit, competent and with no criminal records.
- 51.5 The installations where job is to be carried out are live and have hydrocarbon environment, CONTRACTOR shall comply with all safety and security rules and regulations and other rules laid down by OWNER for its operation. CONTRACTOR shall follow best Engineering practice and relevant international safety standards. It shall be duty / responsibility of the CONTRACTOR to ensure the compliance of fire safety, security and other operational rules and regulations by his personnel. Disregard to these rules by the CONTRACTOR's personnel will lead to the termination of the CONTRACT in all respects and shall face penal / legal consequences.
- 51.6 CONTRACTOR shall obtain and keep valid and subsisting requisite insurance policy for all his personnel deployed on the job during the period on contract as per the provisions of ILO of OHS and submit a copy of the same to SIPI Compliance Team for information and records. Contractor shall pay compensation to his personnel in case of any accidental injury in



**SUPPLY OF CARBON STEEL FLANGES AND FITTINGS
AT COTONOU, BENIN OF WEST AFRICA**



Tender Document No:
A I I P / R E P L / 0 1 1 / C S F

Date: 31/03/2023

accordance with the provisions of ILO of OHS. In case by virtue of provisions of law in force, OWNER has to pay compensation for workmen employed by the CONTRACTOR due to any cause whatsoever, the amount so paid shall be recovered from the dues payable to the CONTRACTOR and/or security deposit with OWNER.

- 51.7 Any failure or non-compliance of the Labour Laws and other rules and regulations to be complied there under the same shall be recoverable by the OWNER from the CONTRACTOR's bills or Retention Money or by revoking the performance bank guarantee.
- 51.8 Contractor shall make payment & settle full & final statutory dues payable to his personnel upon completion of the contract as per provisions of applicable law. Contractor shall be directly responsible to indemnify the OWNER against all charges, claims, dues, etc. arising out of disputes relating to the dues and employment of personnel deployed by him.



**SUPPLY OF CARBON STEEL FLANGES AND FITTINGS
AT COTONOU, BENIN OF WEST AFRICA**



Tender Document No:
A I I P /REPL/011/CSF

Date: 31/03/2023

SECTION-IV

SPECIAL CONDITIONS OF CONTRACT (SCC)



**SUPPLY OF CARBON STEEL FLANGES AND FITTINGS
AT COTONOU, BENIN OF WEST AFRICA**



Tender Document No:
A I I P / R E P L / 0 1 1 / C S F

Date: 31/03/2023

SPECIAL CONDITIONS OF THE CONTRACT (SCC)

- 1. TENDER EVENT DAYS:** If any Tender event day is falling on general holidays. Next working Day shall be considered for the Tender event.
- 2. PBG REFUND TERMS:** PBG shall be refunded at 3 months post contract completion period.
- 3. PAYMENT TERMS:**
30% payment against inspection reports and 70% after against receipt of material.

4. DELIVERY AND DOCUMENTS

4.4 Upon delivery of the Goods to the transporters/carriers, the Supplier shall notify the Purchaser/ Consultant through fax/mail the documents. The bidder will also indicate likely date of arrival to the Purchaser/ Consultant:

- a) BOL
- b) Packing List showing weight and dimension of each package
- c) Material Test Certificate
- d) Manufacturer's factory inspection complying the technical specification as per tender
- e) Inspection release note issued by Purchaser/ Consultant/ TPIA
- f) Guarantee / Warranty Certificate
- g) Dispatch clearance issued by Purchaser/ Consultant
- h) Invoice

5. DELIVERY SCHEDULE:

- 5.1** Dispatch (Ready for Shipment) of CS Flanges & Fittings shall be within 08 weeks of LOA.
- 5.2** Basis of Delivery: The basis of delivery shall be FOB: Port, country of origin.
- 5.3** PRS Applicability: Date of Bill of Laden (BOL) shall be considered as date of dispatch.

6 BID EVALUATION CRITERIA: Bids submitted by bidder will be evaluated on Total Quoted Price.

7 QUANTITY: As Per SOR.

8 UNDERTAKING FOR BLACKLISTING: Bidder shall provide undertaking on their letterhead, confirming they are not on blacklisting or on holiday at SIPI. This is mandatory to submit the letter along with Bid.

9 DEFECT LIABILITY PERIOD: warranty period shall be 12 months from the the date of supply, whichever is earlier. Detailed clause shall be as per Technical Vol.

10 PRICE REDUCTION SCHEDULE (PRS)

Time is the essence of the CONTRACT. In case the CONTRACTOR fails to complete the WORK within the stipulated period, then, unless such failure is due to Force Majeure as defined in Clause 26 here above or due to EMPLOYER's defaults, the Total Contract price shall be

reduced by ½ % of the total Contract Price per complete week of delay or part thereof subject to a maximum of 5 % of the Total Contract Price, by way of reduction in price for delay and not as penalty. The said amount will be recovered from amount due to the Contractor/ Contractor's Contract Performance Security payable on demand.

The decision of the ENGINEER-IN-CHARGE in regard to applicability of Price Reduction Schedule shall be final and binding on the CONTRACTOR.

All sums payable under this clause is the reduction in price due to delay in completion period at the above agreed rate.

11 CONTRACT-CUM-EQUIPMENT PERFORMANCE BANK GUARANTEE (CPBG)

- 13.1 Within thirty (30) Days of receipt of the Letter of Acceptance / Notification of Award, the successful bidder shall furnish to the Purchaser the Contract-Cum-Equipment Performance Bank Guarantee (CPBG) of **5%** of total order value / contract value (Total order value will be as per SOR)
- 13.2 Contract Performance Bank Guarantee shall be confirmed by bidder's bank, any confirmation charges shall be borne by bidder.
- 13.3 All bank guarantees will also have 30 days claim period beyond expiry date.
- 13.4 The proceeds of the Contract-Cum-Equipment Performance Bank Guarantee shall be payable to the Purchaser as compensation for any loss or damage resulting from the Supplier's failure to complete its obligations under the Agreement.
- 13.5 The Contract-Cum-Equipment Performance Bank Guarantee shall be denominated in the currency of the Contract/ Letter of award.
- 13.6 The Contract Performance Guarantee will be discharged by the Purchaser and returned to the Supplier not later than thirty (30) days following the date of completion of all the Supplier's performance obligations under the Contract, including any warranty obligations.
- 13.7 The CPBG shall be valid up to one (01) year.



**SUPPLY OF CARBON STEEL FLANGES AND FITTINGS
AT COTONOU, BENIN OF WEST AFRICA**



Tender Document No:
A I I P /REPL/011/CSF

Date: 31/03/2023

**SECTION - V
FORMS & FORMATS**



**SUPPLY OF CARBON STEEL FLANGES AND FITTINGS
AT COTONOU, BENIN OF WEST AFRICA**



Tender Document No:
A I I P / R E P L / 0 1 1 / C S F

Date: 31/03/2023

**Form 1
BIDDER'S GENERAL INFORMATION
(Information must be provided on bidder's letterhead)**

1-1 Bidder Name: _____

1-2 Number of Years in Operation: _____

1-3 Address of Registered Office: _____

City _____ District _____

State _____ Country _____

1-4 Operation Address
(If different from above): _____

City _____ District _____

State _____ Country _____

1-5 Telephone Number: _____
(Area Code) (Telephone Number)

1-6 Mobile Number, if any _____

1-7 E-mail address: _____

1-8 Website: _____

1-9 Fax Number: _____
(Area Code) (Telephone Number)

1-10 ISO Certification, if any {If yes, please furnish details} _____

1-11 Bank's Name : _____

1-12 Bank's Branch Address: _____

1-13 Bank Branch Code: _____

1-14 Bank account number: _____



**SUPPLY OF CARBON STEEL FLANGES AND FITTINGS
AT COTONOU, BENIN OF WEST AFRICA**



Tender Document No:
A I I P / R E P L / 0 1 1 / C S F

Date: 31/03/2023

1-15 IFSC Code: _____

1-16 MICR Code: _____

1-17 Type of Firm: Proprietary/ Partnership/ PVT/Public Ltd.: _____

1-18 If others, please specify _____

1-19 Details of Directors/ Proprietors/ Partners _____

(Kindly attach separate sheets giving details for name of directors / proprietors and their stakes) along with the supporting documents.

1-20 If unregistered (Reason)

- a) Turnover threshold
- b) Providing exemption goods/services
- c) Others (specify)

(SIGNATURE OF BIDDER WITH SEAL)

Note:

- 1 The above required information is required on the bidder's letterhead.
- 2 Bidders have to submit supporting documents for the above details including the following:
 - a. Cancelled cheque of the bank account mentioned above



**SUPPLY OF CARBON STEEL FLANGES AND FITTINGS
AT COTONOU, BENIN OF WEST AFRICA**



Tender Document No:
A I I P / R E P L / 0 1 1 / C S F

Date: 31/03/2023

Form 2

"NO DEVIATION" CONFIRMATION

To
SIPI-Bénin, Glo-Djigbé Industrial
Zone(GDIZ) 201, Building
Residence Océane – Block: 612 –
District: Patte d'oie – Plot: ZA – 04
BP 612 ☎ +229 21 30 12 13
Sub:
Tender no:

Dear Sir,
We understand that any 'deviation / exception' in any form may result in rejection of Bid.
We, therefore, certify that we have not taken any 'exception / deviation' anywhere in the
Bid and we agree that if any 'deviation / exception' is mentioned or noticed, our Bid may
be rejected.

Place

Date:

Name:

Designation:

Seal: (Signature of the bidder)



**SUPPLY OF CARBON STEEL FLANGES AND FITTINGS
AT COTONOU, BENIN OF WEST AFRICA**



Tender Document No:
A IIP /REPL/011/CSF

Date: 31/03/2023

Form 3

**FORMAT FOR CERTIFICATE FROM STATUTORY AUDITOR FOR DETAILS OF SIMILAR GOODS/ WORK/ SERVICES SUPPLIED/ DONE
DURING PAST 5 YEARS**

(Applicable in all cases where bidder's accounts are audited by Statutory Auditor)

Sr. no.	Description of the goods/ works/ services	LOA/ PO/ WO no. & date	Full proposal, address & phone nos. of client Name, designation & address of engineer/officer-in-charge (for cases other than purchase)	Value of Contract/ Order (Specify Currency amount)	Date of Commencement of work/ services or supply of goods	Scheduled completion time (months) delivery schedule	Date of actual completion/ supply	Reasons for delay in execution if any	Project cost
(1)	(2)	(3)	(4)	(5)	(6)	(7)	(8)	(9)	(10)



Place:

Date:

[Sign. Of authorized signatory of bidder]

Name:

Designation:

	SUPPLY OF CARBON STEEL FLANGES AND FITTINGS AT COTONOU, BENIN OF WEST AFRICA	
Tender Document No: A IIP /REPL/011/CSF		Date: 31/03/2023

Instructions:

1. Copies of letter of awards/ order/ work orders and completion certificate (in case of works/services) or IRN/ Proof of delivery (in case of supplies, if applicable) to be enclosed.

Note: Completion certificate shall clearly mention the LOA/ PO/ WO no. along with the total awarded value and total executed value separately (under a single Contract/ PO/ WO/ LOA), otherwise completion of such contract/ order shall not be considered for evaluation.

2. The supply/ work/ services completed earlier than 5 years shall not be indicated here.
3. The list of supply/ work/ services not of similar nature shall not be indicated here. Failing to comply aforementioned instructions may lead to rejection of bid.
4. Bidders are expected to provide details in respect of each order in this Annexure. The orders cited must comply with the bid evaluation criteria specified in Tender Document. Details provided in this section is intended to serve as a backup for information provided in Offer/ Quotation. Bidder should also refer to the instructions below.
5. A separate sheet should be filled for each LOA/ work order/ purchase order.
6. Certificate from the bidder's statutory auditors must be furnished in the format below for LOA/ Work Order/ Purchase Order mentioned above (separately for each order)

It may be noted that in the absence above certificates, the details would be considered inadequate and could lead to the bid being considered ineligible for further evaluation.



**SUPPLY OF CARBON STEEL FLANGES AND FITTINGS
AT COTONOU, BENIN OF WEST AFRICA**



Tender Document No:
A IIP /REPL/011/CSF

Date: 31/03/2023

F-4

**E-Banking Mandate Form
(To be issued on vendors letter head)**

1. Vendor/customer Name :
2. Vendor/customer Code:
3. Vendor /customer Address:
4. Vendor/customer e-mail id:
5. Particulars of bank account
 - a) Name of Bank
 - b) Name of branch
 - c) Branch code:
 - d) Address:
 - e) Telephone number:
 - f) Type of account (current/saving etc.)
 - g) Account Number:
 - h) RTGS IFSC code of the bank branch
 - i) NEFT IFSC code of the bank branch
 - j) 9 digit MICR code

I/We hereby authorize SIPI to release any amount due to me/us in the bank account as mentioned above. I/We hereby declare that the particulars given above are correct and complete. If the transaction is delayed or lost because of incomplete or incorrect information, we would not hold the SIPI responsible.

(Signature of vendor/customer)

BANK CERTIFICATE

**We certify that ----- has an Account no. -----
with us and we confirm that the details given above are correct as per our
records.**

Bank stamp

Date (Signature of authorized officer of bank)



**SUPPLY OF CARBON STEEL FLANGES AND FITTINGS
AT COTONOU, BENIN OF WEST AFRICA**



Tender Document No:
A IIP /REPL/011/CSF

Date: 31/03/2023

**Form 5
CERTIFICATE FROM THE STATUTORY AUDITOR REGARDING SUPPLY OF
GOODS/WORKS/SERVICES**

Based on its books of accounts and other published information authenticated by it, {this is to certify that LOA/ PO/ WO no.dated.....was awarded to (Name of the bidder) by..... (Name of the client) to execute..... (Name of the supply/ work/ service). The Supply/ works/ services commenced on (Date) was/ is likely to be completed on (Date, if any). It is certified that the total value of contract/order executed by..... (Name of bidder) was (Specify currency & amount) and executed value was(Specify currency & amount).

Name of Audit Firm:
[Signature of authorized signatory]

Chartered Accountant:

Date:
Designation:
Seal:
Membership no.

Name:



**SUPPLY OF CARBON STEEL FLANGES AND FITTINGS
AT COTONOU, BENIN OF WEST AFRICA**



Tender Document No:
A I I P / R E P L / 0 1 1 / C S F

Date: 31/03/2023

**Form 6
CERTIFICATE FOR FINANCIAL CAPABILITY OF THE BIDDER
FORMAT FOR STATUTORY AUDITOR'S / CHARTERED ACCOUNTANT*
(For supply of Goods/Works/Services)**

We have verified the Annual Accounts and other relevant records of M/s. _____
(Name of bidder) and certify the following:

ANNUAL TURN OVER OF LAST 3 YEARS:

Year	Amount (EURO)
Year1: 20_ - ____	
Year2: 20_ - ____	
Year3: 20_ - ____	

FINANCIAL DATA FOR LAST AUDITED FINANCIAL YEAR:

Description	Year 20_ - ____ Amount (EURO)
1. Currency Assets	
2. Current liabilities	
3. Working capital (Current assets-current liabilities)	
4. Net worth (Paid up share capital and free reserves & surplus)	

Name of Audit Firm:
Chartered Accountant
Date:
Membership No.

[Signature of Authorized signatory]
Name:
Designation: Seal:

Instructions:

- The financial year would be the same as one normally followed by the bidder for its Annual Report.
- The bidder shall provide the audited annual financial statements as required for this Tender Document. Failure to do so would result in the personal being considered as non-responsive.
- for the purpose of this Tender document (i) Annual Turnover shall be "Sale value/ Operating income" (ii) Working capital shall be "Current Assets less Current Liabilities" and (iii) Net Worth shall be "Paid up share capital and Free reserves & Surplus".
- *Bidders whose accounts are not audited by auditors as per Law/jurisdiction, certification from a Chartered Accountant to be submitted.

(SIGNATURE OF BIDDER WITH SEAL)



**SUPPLY OF CARBON STEEL FLANGES AND FITTINGS
AT COTONOU, BENIN OF WEST AFRICA**



Tender Document No:
A I I P / R E P L / 0 1 1 / C S F

Date: 31/03/2023

DECLARATION

(On Bidder's letter head)

To
SIPI-Bénin, Glo-Djigbé Industrial
Zone(GDIZ) 201, Building Residence
Océane – Block: 612 – District: Patte
d'oie – Plot: ZA – 04 BP 612 ☎ +229
21 30 12 13

We confirm that we are not under any liquidation, court receivership or similar proceedings.

We also confirm that we have not been banned or delisted by any government (national, state or local governments), PSU, PSU-JV, government ministry and/ or other government entities from quoting.

SEAL AND SIGNATURE OF BIDDER



**SUPPLY OF CARBON STEEL FLANGES AND FITTINGS
AT COTONOU, BENIN OF WEST AFRICA**



Tender Document No:
A I I P / R E P L / 0 1 1 / C S F

Date: 31/03/2023

**DECLARATION OF TENDER DOCUMENT PURCHASED/ DOWNLOADED
(On Bidder's letter head)**

Date:

To
SIPI-Bénin, Glo-Djigbé Industrial
Zone(GDIZ) 201, Building
Residence Océane – Block: 612 –
District: Patte d'oie – Plot: ZA – 04
BP 612 ☎ +229 21 30 12 13

Sub: Bid Document no. _____

Sir,

We hereby confirm that we have read each page of the subject tender document along with Corrigendum & Reply to bidder's queries thoroughly and understood the complete Scope of Work and other terms & conditions. We hereby also confirm that tender terms & conditions are acceptable to us and any deviation other than mentioned in deviation form is not to be taken into account. Also, no alterations have been made to the original tender document as provided by SIPI-Benin.

Yours faithfully,

Signature
Name & Designation
For and on behalf of



**SUPPLY OF CARBON STEEL FLANGES AND FITTINGS
AT COTONOU, BENIN OF WEST AFRICA**



Tender Document No:
A IIP/REPL/011/CSF

Date: 31/03/2023

COVERING LETTER ON LETTER HEAD FOR STATUTORY AUDITOR

To,

Date:

Subject: Certificate regarding

Dear Sir,

We..... (Name of the Statutory Auditor/ Chartered Accountant) are the Statutory Auditor/ Chartered Accountant of M/s. (Name of the bidder).

We hereby confirm that we have issued following certificate:

- 1.
- 2.
- 3.

Thanking You,

Place:
Date:
Membership No.
Encl.: As above

(Signature)
Name of Authorized Signatory

Note:

Bidder whose accounts are not audited by the auditors as per law/ jurisdiction, certification from Chartered Accountant to be submitted.



**SUPPLY OF CARBON STEEL FLANGES AND FITTINGS
AT COTONOU, BENIN OF WEST AFRICA**



Tender Document No:
A IIP/REPL/011/CSF

Date: 31/03/2023

PROFORMA FOR LETTER OF AUTHORITY

Date:

SIPI-Bénin, Glo-Djigbé Industrial
Zone(GDIZ) 201, Building Residence
Océane – Block: 612 – District: Patte
d'oie – Plot: ZA – 04 BP 612 ☎ +229
21 30 12 13

Sub: Bidding Document for

Sir,

We _____ hereby authorize following representative(s) to attend the Un-priced Bid opening and Priced Bid opening against above Bidding Document:

- | | | |
|----|-------------------------|-----------------|
| 1. | Name & Designation_____ | Signature _____ |
| 2. | Name & Designation_____ | Signature _____ |



We confirm that we shall be bound by all and whatsoever our representative(s) shall commit.

Yours faithfully,

Signature
Name & Designation
For and on behalf of

Note: This letter of authority should be on the letterhead of the bidder and should be signed by a person competent and having the power of attorney to bind the bidder.

SEAL OF THE COMPANY

	SUPPLY OF CARBON STEEL FLANGES AND FITTINGS AT COTONOU, BENIN OF WEST AFRICA	 Resonance Energy
Tender Document No: A IIP/REPL/011/CSF		Date: 31/03/2023

Form F-11

Details of litigation (on Bidder's letter head)

Bidder shall furnish details of litigation cases of the bidder during the last 5 years if any, in this Form.



**SUPPLY OF CARBON STEEL FLANGES AND FITTINGS
AT COTONOU, BENIN OF WEST AFRICA**



Tender Document No:
A IIP/REPL/011/CSF

Date: 31/03/2023

FORM F-12: FORMAT FOR BIDDERS QUERIES & IT'S REPLY

QUERIES RAISED DURING PRE-BID MEETING BY BIDDER AND REPLY / CLARIFICATION TO BIDDERS

BY OWNER

Tender No.:	Date / Time of Pre- Bid :
--------------------	----------------------------------

Venue:	Date of Pre-bid Clarifications:
---------------	--

Tender Description:

Bidder Name :

Sr.	Tender Clause No /Annexure	Page No.	Clause Description	Bidders Comments /Queries	Owner Reply / Clarifications toBidders
1					
2					
3					
4					
5					
6					
7					
8					
9					
10					
11					
12					
13					
14					

SIGNATURE AND SEAL OF BIDDER



**SUPPLY OF CARBON STEEL FLANGES AND FITTINGS
AT COTONOU, BENIN OF WEST AFRICA**



Tender Document No:
A IIP /REPL/011/CSF

Date: 31/03/2023

SECTION - VII

OTHER FORMS APPLICABLE AFTER AWARD



**SUPPLY OF CARBON STEEL FLANGES AND FITTINGS
AT COTONOU, BENIN OF WEST AFRICA**



Tender Document No:
A IIP/REPL/011/CSF

Date: 31/03/2023

CONTRACT – PERFORMANCE BANK GUARANTEE
(To be stamped in accordance with Stamp Act)

Ref: Bank Guarantee No.....
Date.....

To
SIPI-Benin

PURCHASER ORDER NO.....DATED.....

Dear Sir,

In consideration of the SIPI-Benin (hereinafter referred to as thePURCHASER which expression shall unless repugnant to the context or meaning thereof include its successors, administrators and assigns) having awarded the work of tohaving its Principal Office at (hereinafter referred to as "VENDOR(SELLER)/"CONTRACTOR)" which expression shall unless repugnant to the context or meaning thereof include their respective successors, administrators, executors and assigns) the supply/execution by issue of PURCHASER'S Purchaser order No. dated And the same having been accepted by the VENDOR(SELLER/CONTRACTOR) resulting into CONTRACTS for supplies of materials equipments/execution of works/services as per above Purchaser Order having a total value of.....for the complete supply of materials/equipments/execution of works/services and the VENDOR(SELLER/CONTRACTOR) having agreed to provide a Contract performance and Warranty/Guarantee for the faithful performance of the aforementioned contract and warranty to quality to PURCHASER.

We (Bank)having its Head Office at..... (hereinafter referred to as the 'Bank' which expression shall unless repugnant to the context or meaning thereof, include its successors, administrators, executors and assigns) do hereby guarantee and undertake to pay the PURCHASER/PURCHASER, on demand any and all moneys payable by the seller/Contractor to the extent of _% (_____percent) of the Contract price without any deviation and protest as aforesaid at any time up to...and without reference to the VENDOR(SELLER/CONTRACTOR). Any such demand made by PURCHASER on the Bank shall be conclusive and binding notwithstanding any difference between PURCHASER and VENDOR(SELLER/CONTRACTOR) or any dispute pending before any Court, Tribunals, Arbitrator or any other Authority.

The Bank undertakes not to revoke this guarantee during its currency without previous consent of PURCHASER and further agrees that the guarantee herein contained shall continue to be enforceable till the PURCHASER discharges the guarantee. PURCHASER shall have the fullest liberty without affecting in any way the liability of theBANK under this guarantee from time to time to extend the time for performance by VENDOR(SELLER/CONTRACTOR) of the aforementioned contract. PURCHASER shall have the fullest liberty, without affecting this guarantee, to postpone from time to time the exercise of any powers vested in them or of any right which they might have against VENDOR(SELLER/CONTRACTOR) and to exercise the same at any time in any manner, and either to enforce to forebear to enforce any covenants contained or implied, in the aforementioned Contracts between PURCHASER and VENDOR(SELLER/CONTRACTOR) or any othercourse of or remedy or security available to PURCHASER. The BANK shall not be released of its obligations under these presents by any exercise by PURCHASER of its liability with reference to the matters aforesaid or any of them or by reason or any other acts of omission or commission on the part of PURCHASER or any other indulgence shown by PURCHASER or by any other matter or thing whatsoever which under law would, but for thisprovisions, have the effect of relieving the BANK.



**SUPPLY OF CARBON STEEL FLANGES AND FITTINGS
AT COTONOU, BENIN OF WEST AFRICA**



Tender Document No:
A I I P / R E P L / 0 1 1 / C S F

Date: 31/03/2023

Bank Guarantee No.....
Date.....

The BANK also agrees that PURCHASER at its option shall be entitled to enforce this Guarantee against the BANK as a Principal Debtor, in the first instance without proceeding against VENDOR(SELLER/CONTRACTOR) and notwithstanding any security or other guarantee that PURCHASER may have in relation to the VENDOR'S(SELLER'S/CONTRACTOR'S) liabilities.

Notwithstanding anything contained herein above our liability under this Guarantee is restricted to AND it shall be remain in force upto and including and shall be extended from time to time for such period as may be desired by the VENDOR(SELLER/CONTRACTOR) on whose behalf this Guarantee has been given.

Dated this the _____ day of _____ 2021 at _____

1. *The guarantee shall not be affected by any change in constitution of the bank or by absorption/merger of bank with any other body or corporation.*
2. *The guarantee shall be in addition to and not in substitution for any other guarantees or security for the supplier/Contractor given or to the Purchaser in respect of said purchase order by the bank (whether alone or jointly with others.*
3. *The bank hereby declares that _____ (Name of the person signing on behalf of bank) _____ is authorized to sign this guarantee /undertaking on behalf of the bank and to bind the bank thereby.*
4. *Any notice by way of request, demand or otherwise hereunder may be sent by post/courier to the bank address and duly verified by proof of delivery will be sufficient & shall be deemed as claim lodging date by Purchaser.*
5. *This guarantee is operative at _____ in Benin (name and address of the branch) branch, _____ (Place).*
6. *Details of issuing and operating branches are as under:*

	Outstation Bank details	Local Operating bank details. (Benin)
Postal Address		
Telephone no / Fax No		
Contact person		
Email ID		

7. *These present shall be governed by and construed in accordance to Republic of Benin law.*



**SUPPLY OF CARBON STEEL FLANGES AND FITTINGS
AT COTONOU, BENIN OF WEST AFRICA**



Tender Document No:
A I I P / R E P L / 0 1 1 / C S F

Date: 31/03/2023

Bank Guarantee No.....
Date.....

Notwithstanding anything contained herein above:-

1. *Our liability under this Bank Guarantee shall not exceed Rs ----- (amount in word).*
2. *This Bank Guarantee shall be valid up to.....*
3. *We are liable to pay the guaranteed amount or any part thereof under this Guarantee only and only if you serve upon written claim or demand on or before --”(1 month beyond expiry date.)*

*WITNESS
(Signature)*

*(Name)
(Official Address)*

(Signature Bank Signatory)

*Bank Rubber Stamp
(Name)*

*Designation with Bank
Stamp plus Attorney as
Per Power of Attorney*

*No.....
Dated.....*

TENDER NO. -: AIIP/REPL/011/CSF

TECHNICAL VOLUME - II OF II



**SUPPLY OF CARBON STEEL FLANGES AND FITTINGS AT
COTONOU, BENIN OF WEST AFRICA**



Tender Document No:
:A IIP /REPL/011/CSF

Date: 31/03/2023

CONTENTS

- Section-I : MATERIAL REQUISITION**
- Section-II : TECHNICAL SPECIFICATION**
- a) Technical Specification for SEAMLESS CS FITTINGS & FLANGES
 - b) Technical Specification for Flow Tee
- Section –III : Data sheets & Sample QAP for CS FITTINGS & FLANGES**
- a) DATA SHEET FOR FLOW TEE -10"X10" NB
 - b) DATA SHEET FOR FLOW TEE - Size-12"X12" NB
 - c) Annexure A – Sample QAP for flanges, SW fittings & BW fittings
 - d) Annexure B : Sample QAP for Flow Tee



**SUPPLY OF CARBON STEEL FLANGES AND FITTINGS AT
COTONOU, BENIN OF WEST AFRICA**



Tender Document No:
:A IIP/REPL/011/CSF

Date: 31/03/2023

MATERIAL REQUISITION

Sr. No	Item Description	Unit	Qty.
A	Manufacture, inspection, testing, packing, supply, transportation and unloading of Carbon Steel Fittings upto 12” Size as defined in bid document		
1	4" WNRF, ASTM A105 SCH STD 600# S80	Nos	22
2	4" BLRF, ASTM A105 SCH STD 600# S80	Nos	22
3	WELDOLET 12"x4" ASTM A234, SCH 80, 600#	Nos	22
4	10" x 10" Equal Tee ASTM A234 Gr. B WPB Sch. STD. 600#	Nos	2
5	12" x 12" Equal Tee ASTM A234 Gr. B WPB Sch. STD. 600#	Nos	2
6	12" x 10" Reducer ASTM A234 Gr. B WPB Sch. STD 600#	Nos	2
7	10" End Cap ASTM S40 A234 WPB 600#	Nos	1
8	12" End Cap ASTM S40 A234 WPB 600#	Nos	2
9	12" 3D Elbow -90° ASTM A 234 Gr.WPB Sch.STD 600#"	Nos	20
10	12" 3D Elbow -45° ASTM A 234 Gr.WPB Sch.STD 600#"	Nos	30
11	12" 3D Elbow -22½° ASTM A 234 Gr.WPB Sch.STD 600#"	Nos	30
12	12" 3D Elbow -11½° ASTM A 234 Gr.WPB Sch.STD 600#"	Nos	30
13	12" 3D Elbow -15° ASTM A 234 Gr.WPB Sch.STD 600#"	Nos	30



**SUPPLY OF CARBON STEEL FLANGES AND FITTINGS AT
COTONOU, BENIN OF WEST AFRICA**



Tender Document No:
:A IIP/REPL/011/CSF

Date: 31/03/2023

14	6" 3D Elbow -90° ASTM A 234 Gr.WPB Sch.STD 300#"	Nos	12
15	6" 3D Elbow -45° ASTM A 234 Gr.WPB Sch.STD 300#"	Nos	02
16	6" 3D Elbow -22½° ASTM A 234 Gr.WPB Sch.STD 300#"	Nos	02
17	6" 3D Elbow -15° ASTM A 234 Gr.WPB Sch.STD 300#"	Nos	04
18	6" x 6" Equal Tee ASTM A234 Gr. B WPB Sch. STD. 300#	Nos	04
19	6" BLRF, ASTM A105 SCH STD 300# S40	Nos	06
20	6" WNRF, ASTM A105 SCH STD 300# S40	Nos	06

Note :- Bidder to submit the CS Flanges and Fitting as per existing Line pipe of SIPI-Benin.

Existing Line pipe specification are as under,

- 1. For 12" – API 5L , 3LPE coated, X-60 Grade, Thickness – 8.4 mm**
- 2. For 10" – API 5L, 3 LPE coated, X-70 Grade, Thickness – 9.27 mm**
- 3. For 6" – API 5L, 3LPE coated, X-52 Grade, Thickness – 8.4 mm**



**SUPPLY OF CARBON STEEL FLANGES AND FITTINGS AT
COTONOU, BENIN OF WEST AFRICA**



Tender Document No:
:A IIP /REPL/011/CSF

Date: 31/03/2023

SECTION -II

TECHNICAL SPECIFICATION

FOR CS FITTINGS & FLANGES



SUPPLY OF CARBON STEEL FLANGES AND FITTINGS AT COTONOU, BENIN OF WEST AFRICA



Tender Document No:
:A IIP/REPL/011/CSF

Date: 31/03/2023

1.0 **SCOPE**

- This specification covers the minimum requirements for the design, manufacture and supply of following items to be installed in pipeline system handling hydrocarbons in liquid or gaseous phase:
- Seamless fittings 400 mm (16") NB and smaller, such as tees, elbows, reducers and caps.
- Flanges 400 mm (16") NB and smaller, such as welding neck flanges and blind flanges.
- The specification does not cover the above mentioned items which are to be installed in pipeline system handling sour hydrocarbons (liquid/ gas) service as defined in NACE standard MR-01-75-98.

2.0 **REFERENCE DOCUMENTS**

Reference has been made in this specification to the latest edition of the following codes, standards and specifications:

- a) ASME B 16.5 - Steel Pipe Flanges and Flanged Fittings
- b) ASME B 16.9 - Factory-Made Wrought Steel Butt Welding Fittings
- c) ASME B 16.11 - Forged Steel Fittings, Socket Welding and Threaded
- d) ASME B 31.4 - Liquid Transportation Systems for Hydrocarbons, Liquid Petroleum Gas, Anhydrous Ammonia and Alcohols
- e) ASME B 31.8 - Gas Transmission and Distribution Piping Systems
- f) ASTM A 370 - Mechanical Testing of Steel Products
- g) API 590 - Steel Line Blanks
- h) MSS-SP-25 - Standard Marking System for Valves, Fittings, Flanges and Unions
- i) MSS-SP-44 - Steel Pipeline Flanges
- j) MSS-SP-75 - Specification for High Test Wrought Welded Fittings
- k) MSS-SP-97 - Forged Carbon Steel Branch Outlet Fittings-Socket Welding, Threaded and Butt Welding End

3.0 **MANUFACTURER'S QUALIFICATION**

Manufacturer who intends bidding for fittings, must possess the records of a successful proof test, in accordance with the provisions of ASME B 16.9/ MSS-SP-75, as applicable. These records shall be submitted at the time of bidding.



SUPPLY OF CARBON STEEL FLANGES AND FITTINGS AT COTONOU, BENIN OF WEST AFRICA



Tender Document No: :A IIP/REPL/011/CSF

Date: 31/03/2023

4.0 MATERIALS

4.1 The basic material for fittings and flanges shall be as indicated in the Material Requisition. Additionally, the material shall also meet the requirements specified hereinafter.

1.2 Each heat of steel used for the manufacture of fittings and flanges shall have carbon equivalent (CE) not greater than 0.43% calculated from check analysis in accordance with following formula :

$$CE = C + \frac{Mn}{6} + \frac{Cr + Mo + V}{5} + \frac{Ni + Cu}{15}$$

Carbon contents on check analysis shall not exceed 0.22%.

1.3 Unless specified otherwise, Charpy V-notch test shall be conducted for each heat of steel, in accordance with the impact test provision of ASTM A370 at (-) 29°C temperature. The average absorbed impact energy values of three full-sized specimens shall be 27 joules. The minimum impact energy value of any one specimen of the three specimens analysed as above, shall not be less than 80% of the above-mentioned average value.

4.4 Steel used shall fully killed.

4.5 Hardness testing shall be carried out by Manufacturer in accordance with ASTM A 234. Hardness testing shall cover at least 10% per item, per size, per heat per manufacturing method.

5.0 DESIGN AND MANUFACTURE

5.1 Flanges such as welding neck flanges and blind flanges shall conform to the requirements of ASME B 16.5. The Raised face of the flanges shall be 125-200 microinches AARH.

Spectacle blind, spacer & blind shall conform to API 590.

5.2 Fittings such as tees, elbows and reducers shall be seamless type and shall conform to ASME B 16.9 for sizes 50 mm (2'')NB and above and ASME B16.11 for sizes below 50mm(2'')NB.

5.3 Fittings such as weldolets, sockolets, nippolets, etc., shall be manufactured in accordance with MSS-SP-97.

5.4 Type, face and face finish of flanges shall be as specified in Material Requisition.

5.5 Stub-in or pipe to pipe connection shall not be used in the manufacture of tees. Tees shall be



**SUPPLY OF CARBON STEEL FLANGES AND FITTINGS AT
COTONOU, BENIN OF WEST AFRICA**



Tender Document No:
:A IIP /REPL/011/CSF

Date: 31/03/2023

manufactured by forging or extrusion methods. The longitudinal weld seam shall be kept at 90° from the extrusion. Fittings shall not have any circumferential joint .

5.6 All butt weld ends shall be beveled as per ASME B16.25.

5.7 Repair by welding on flanges and parent metal of the fittings is not allowed.

6.0 **INSPECTION AND TESTS**

6.1 The Manufacturer shall perform all inspection and tests as per the requirement of this specification and the relevant codes, prior to shipment at his works. Such inspection and test shall be, but not limited to, the following:

6.1.1 Visual inspection.

Dimensional checks.

6.1.2 Chemical composition, mechanical properties and hardness examination.

6.1.3 All finished wrought weld ends shall be 100% ultrasonically tested for lamination type defects. Any lamination larger than 6.35 mm shall not be acceptable.

6.1.4 All other tests not specifically listed but are required as per applicable standard/ specification. Spectacle blind, spacer & blind shall conform to API 590.

6.2 Purchaser's Inspector may also perform stage-wise inspection and witness tests as indicated in Clause 6.1 at Manufacturer's Works prior to shipment. Manufacturer shall give reasonable notice of time and shall provide, without charge, reasonable access and facilities required for inspection to the Purchaser's Inspector.

Inspection and tests performed/ witnessed by the Purchaser's Inspector shall in no way relieve the Manufacturer's obligation to perform the required inspection and tests.

Purchaser's Inspector shall perform inspection and witness tests on fittings & flanges as indicated / Approved Quality Assurance Plan (QAP) submitted by the successful bidder. A sample QAP is enclosed as Annexure A for guidance.

7.0 **TEST CERTIFICATES**

Manufacturer shall submit following certificates to Purchaser's Inspector:



**SUPPLY OF CARBON STEEL FLANGES AND FITTINGS AT
COTONOU, BENIN OF WEST AFRICA**



Tender Document No:
:A IIP /REPL/011/CSF

Date: 31/03/2023

- a) Test certificates relevant to the chemical analysis and mechanical properties of the materials used for construction as per this specification and relevant standards.
- b) Test reports on non-destructive testing.

8.0 MARKING

Each item shall be marked with indelible paint with the following data:

9.0 DOCUMENTATION

9.1 At the time of bidding, Manufacturer shall submit the following documents:

- a) Reference list of previous supplies of similar fittings of similar specification.
- b) Clausewise list of deviations from this specification, if any.
- c) Brief description of the manufacturing and quality control facilities at Manufacturer's works.
- d) Manufacturer's qualification requirement as per clause 3.0 of this specification.
- e) Quality Assurance Plan (QAP) enclosed with this tender duly signed, stamped and accepted.

9.2 Prior to shipment, Manufacturer shall submit six copies of test certificates as listed in clause 7.0 of this specification.

9.3 All documents shall be in English language.

- a) Manufacturer's marking
- b) Material Specification
- c) Size and schedule number
- d) Heat number

10.0 Third party inspection:

Bidder shall appoint anyone of the following TPIA for inspection purpose, wherever required as per tender document & QAP attached.

- 1) Lloyd Register of Industrial Services
- 2) TUV SUD South Asia Limited
- 3) Det Norske Veritas (DNV)
- 4) AB-Vincotte
- 5) Bureau Veritas – India
- 6) SGS India Limited
- 7) American Bureau Services
- 8) Velosi Certification Services
- 9) Dr. Amin Controllers Pvt. Limited
- 10) Any other certified TPI Agencies



**SUPPLY OF CARBON STEEL FLANGES AND FITTINGS AT
COTONOU, BENIN OF WEST AFRICA**



Tender Document No:
:A11P/REPL/011/CSF

Date: 31/03/2023

**TECHNICAL SPECIFICATION
FOR
FLOW TEES**



**SUPPLY OF CARBON STEEL FLANGES AND FITTINGS AT
COTONOU, BENIN OF WEST AFRICA**



Tender Document No:
:A11P/REPL/011/CSF

Date: 31/03/2023

CONTENTS

<u>Sl.No.</u>	<u>Description</u>
1.0	SCOPE
2.0	REFERENCE DOCUMENTS
3.0	MANUFACTURER'S QUALIFICATION
4.0	MATERIALS
5.0	DESIGN AND CONSTRUCTION REQUIREMENTS
6.0	INSPECTION AND TESTS
7.0	TEST CERTIFICATES
8.0	PAINTING, MARKING AND SHIPMENT
9.0	WARRANTY
10.0	DOCUMENTATION



SUPPLY OF CARBON STEEL FLANGES AND FITTINGS AT COTONOU, BENIN OF WEST AFRICA



Tender Document No:
:A11P/REPL/011/CSF

Date: 31/03/2023

1.0 **SCOPE**

This specification covers the basic requirements for the design, manufacture and supply of carbon steel flow tees to be installed in pipeline system for handling hydrocarbons in liquid or gaseous phase.

2.0 **REFERENCE DOCUMENTS**

Reference has also been made in this specification to the latest edition of the following codes, standards and specifications:

- a) ASME B 31.4 : Liquid Transportation Systems for Hydrocarbons, Liquid Petroleum Gas, Anhydrous Ammonia and Alcohols.
- b) ASME B 31.8 : Gas Transmission and Distribution Piping System
- c) ASME B 16.9 : Factory made wrought steel butt welding fittings.
- d) ASME Sec. VIII : Boiler & Pressure Vessels Code-Rules for the construction of pressure vessels.
- e) ASME Sec. IX Qualifications. : Boiler & Pressure Vessel Code-Welding & Brazing
- f) ASTM A 370 : Mechanical Testing of Steel Products
- g) MSS-SP-53 : Quality Standard for Steel Castings and Forgings for Valves, Flanges and fittings and other Piping components and - Magnetic Particle Examination Method.
- h) MSS-SP-75 : Specification for High Test Wrought Butt Welding Fittings
- i) API 1104 : Specification for Welding Pipeline and Related Facilities
- j) SSPC-VIS-1 : Steel Structures Painting Council



SUPPLY OF CARBON STEEL FLANGES AND FITTINGS AT COTONOU, BENIN OF WEST AFRICA



Tender Document No:
:A11P/REPL/011/CSF

Date: 31/03/2023

In case of conflict between the requirements of this specification and any code, Standard and Specification referred in Clause 2.1 above. Order of precedence shall be as follows

- Data Sheets
- This Specification
- Other Referred Codes & Standards
- Manufacturer's Standard.

3.0 **MANUFACTURER'S QUALIFICATION**

Manufacturer who intend bidding for flow tees must possess the records of a successful proof test for tees used in the fabrication of flow tees, in accordance with the provisions of ASME B16.9/ MSS-SP-75. These records shall be submitted at the time of bidding.

4.0 **MATERIALS**

4.1 Material for the pressure containing parts of the flow tees shall be indicated in the Data/SOR sheet. Other parts shall be as per manufacturer's standard suitable for the service conditions indicated in Data/SOR sheet and shall be subjected to approval by Purchaser.

4.2 Fully killed Carbon steel shall be used in the manufacture of flow tees.

4.3 Each heat of steel used for the manufacture of pressure containing parts of the flow tees shall have carbon equivalent (CE) not greater than 0.45 calculated from the check analysis in accordance with the following formula.

$$CE = C + Mn/6 + (Cr+Mo+V)/5 + (Ni +Cu)/15$$

4.4 Charpy V-notch test shall be conducted for each heat of steel used in manufacture of pressure containing parts of flow tee as specified in data sheet/Design standard. Test shall conform to the provisions of MSS-SP-75 / ASTM A-370 and at a temperature specified in the data sheet for pressure containing parts material. The Charpy impact test specimen shall be taken in the direction of principal grain flow and notched perpendicular to the original surface of the plate or forging. The average impact energy values of full sized three specimens shall be as specified in the data sheet.

In case if not specified in the data sheet, the Charpy impact test at 0 ° C shall be carried out in conformance to the provisions of MSS SP 75/ASTM A 370 and the average impact energy values of full sized specimens shall be as follows



**SUPPLY OF CARBON STEEL FLANGES AND FITTINGS AT
COTONOU, BENIN OF WEST AFRICA**



Tender Document No:
:A11P/REPL/011/CSF

Date: 31/03/2023

Diameter (inches)	Base Metal (joules)	Weld Metal and HAZ (joules)
For all sizes	27	27

Minimum impact energy value of any one specimen shall not be less than 80% of the above average values.

When Low Temperature Carbon Steel (LCTS) materials are specified in Datasheet or offered by Manufacturer, the Charpy V-notch test requirements of applicable material standard shall be complied with.

- 4.5 When specified in the Data/SOR sheet, hardness test shall be carried out as per ASTM A370 for each heat of steel used. The maximum hardness of base metal, weld metal and HAZ of all pressure containing parts shall be 248 HV₁₀, unless otherwise specified.

5.0 DESIGN AND CONSTRUCTION REQUIREMENTS

- 5.1 Flow tees shall be designed and manufactured in accordance with the provisions of codes and standards referred in Section 2.0 of this specification. Design factor and corrosion allowance indicated in Data sheet shall be taken into account for design of flow-tees.

- 5.2 Flow tees shall generally conform to the figure shown in the Data/SOR sheet and shall meet following requirements as minimum:

- a) An internal pipe having the same diameter as the connecting pipeline allowing the passage of scraper/ instrumented pigs, provided with holes/slots located in the centreline of the branch. The holes shall be oriented at 45° angle. The holes shall be designed to prevent the pig getting stuck or damaged without affecting the flow through the branch line. The area of the holes/slots shall be at least equal to the internal area of branch size.
- b) A forged/ submerged arc welded 'tee' as per ASME B 16.9/ MSS-SP-75 enclosing the internal pipe fixed to it by suitably shaped forged steel rings. Machined steel rings shall not be used. The centre-to-end dimension of the outlet shall meet the minimum recommended dimension of the referred standard. Circumferential welding on the branch outlet is not acceptable. Pup shall not be provided either at the run or at the branch.



**SUPPLY OF CARBON STEEL FLANGES AND FITTINGS AT
COTONOU, BENIN OF WEST AFRICA**



Tender Document No:
:A11P/REPL/011/CSF

Date: 31/03/2023

c) Tees used for fabrication of flow tees shall be seamless type for run sizes $DN \leq 350$ mm (14") and shall be either welded or seamless type for run sizes $DN \geq 400$ mm (16"). Tees shall conform to ASME B16.9 for run size up to DN 350(14"). For run size $DN \geq 400$ mm (16"), the tees shall confirm to MSS-SP- 75/ASME B16.9.

5.3 Butt weld ends shall be beveled as per MSS-SP-75.

5.4 All flow tees shall be completely stress relieved as per MSS-SP-75.

5.5 Stub-in or pipe to pipe connection shall not be used in the manufacture of flow tees. Flowtees shall be manufactured by forging or extrusion methods. In case flow tees are manufactured using welded tees, the longitudinal weld seam shall be at least 90° to the branch connection.

5.6 All welds shall be made by welders and welding procedures qualified in accordance with ASME Section-IX. The welding procedure qualification test shall include charpy impact test and hardness test and shall meet the requirements of clause 4.4 and 4.5 of this specification respectively.

5.7 Repair by welding on parent metal is not allowed. Repair of welds shall be carried out only after specific approval by Purchaser's Representative for each repair. The repair welding shall be carried out by the welders and welding procedures duly qualified as per ASME Section-IX and records for each repair shall be maintained. Repair welding procedure qualification shall include all test, which are applicable for regular production welding procedure qualification.

6.0 **INSPECTION AND TESTS**

6.1 The manufacturer shall perform all inspections and tests as per the requirements of this specification and the relevant codes, prior to shipment, at his works. Such inspection and tests shall be, but not limited to the following:

6.1.1 All flow tees shall be visually inspected. The internal & external surfaces of the flow tees shall be free from any strikes, gauges & other detrimental defects.

6.1.2 Dimensional checks shall be carried out as per the approved drawing.

6.1.3 Chemical composition and Mechanical properties shall be checked as per MSS-SP-75 and this specification for each heat of steel used.



**SUPPLY OF CARBON STEEL FLANGES AND FITTINGS AT
COTONOU, BENIN OF WEST AFRICA**



Tender Document No:
:A11P/REPL/011/CSF

Date: 31/03/2023

6.1.4 Non destructive examination of individual flow tees shall be performed as given below:

- a) 100% inspection by radiography shall be carried out on all butt welds of pressure containing parts. Acceptance limits shall be as per API 1104.
- b) Welds which in Purchaser's Representative's opinion cannot be inspected by radiographic methods shall be checked by ultrasonic or magnetic particle methods. Acceptance criteria shall be as per ASME Section VIII Appendix-12 and Appendix-6 respectively.
- c) Magnetic particle or liquid penetrant examination shall be performed on cold formed butt welding tees with extruded outlets that are subjected to an extreme fiber elongation of greater than 5%. The examination shall be carried out as per the supplementary Requirement SR 3 of MSS-SP- 75.
- d) All finished wrought weld ends shall be 100% ultrasonically tested for lamination type defects for a distance of 25mm from the end. Any lamination larger than 6.35mm shall not be acceptance.
- d) All forgings shall be wet magnetic particle examined on 100% of the forged surfaces. Method and acceptance shall comply with MSS-SP-53.

6.2 Purchaser's Representative shall also perform stagewise inspection and witness tests as indicated in clause 6.1 at manufacturer's works prior to shipment. Manufacturer shall give reasonable notice of time and shall provide without charge reasonable access and facilities required for inspection, to the Purchaser's Representative.

Inspection and tests performed/ witnessed by Purchaser's Representative shall in no way relieve the Manufacturer's obligation to perform the required inspection and tests by TPIA.

Purchaser's Inspector shall perform inspection and witness tests on all flow tees as indicated / Approved Quality Assurance Plan (QAP) submitted by the successful bidder. A sample QAP is enclosed in the tender for guidance.

7.0 **TEST CERTIFICATES**

7.1 Manufacturer shall submit following certificates to Purchaser's Representative:



**SUPPLY OF CARBON STEEL FLANGES AND FITTINGS AT
COTONOU, BENIN OF WEST AFRICA**



Tender Document No:
:A11P/REPL/011/CSF

Date: 31/03/2023

- a) Test certificates relevant to the chemical analysis and mechanical properties of the materials used for construction as per this specification and relevant standards.
- b) Test reports on radiographic and ultrasonic inspection and wet magnetic particle examination.
- c) Certificates for each flow tee stating that it is capable of withstanding without leakage for a test duration of 15 minutes and test pressure which results in a hoop stress equivalent to 95% of the specified minimum yield strength and for the pipe with which the flow tee is to be attached without impairing its serviceability.
- d) Test reports on heat treatment carried out.
- e) Welding Procedures & Welders qualification reports.

8.0 PAINTING, MARKING AND SHIPMENT

- 8.1 Flow tees entire surface shall be thoroughly cleaned, freed from rust and grease and applied with sufficient coats of corrosion resistant paint, after all the required tests have been performed and accepted by Purchaser's Representative. The surface preparation shall be carried out by shot blasting to SP 6 in accordance with "Steel Structures Painting Council - Visual Standard - SSPC-VIS-1".
- 8.2 Manufacturer shall indicate the type & recommended coats of corrosion resistant paint used, in the drawing submitted for approval.
- 8.3 Flow tees shall be marked with indelible paint with the following Data/SOR:
 - a) Manufacturer's Name
 - b) Nominal diameter in inches D1 x D2
 - c) End thickness in mm T1 x T2
 - d) Material
 - e) Tag numbers
- 8.4 Flow tees shall be suitably protected to avoid any damage during transit. Metallic or high impact plastic bevel protectors shall be provided for weld ends.



**SUPPLY OF CARBON STEEL FLANGES AND FITTINGS AT
COTONOU, BENIN OF WEST AFRICA**



Tender Document No:
:A11P/REPL/011/CSF

Date: 31/03/2023

9.0 WARRANTY

Purchaser will be reimbursed by Manufacturer for any flow tee furnished to this specification which fails under field hydrostatic testing or does not perform satisfactory during the pigging operation and if such failure or non-performance is caused by a defect in the flow tees which is outside the acceptance limits of this specification. The reimbursement cost shall include cost of flow tee, labour and equipment rental for finding, excavating, cutting, and installation of replaced flow tee in position.

10.0 DOCUMENTATION

10.1 At the time of bidding, bidder shall submit the following documents: -

- a) General arrangement drawing of flow tees with overall dimensions and details of internal sleeve and cross sectional drawings.
- b) Clause-wise list of deviation from this specification, if any.
- c) Brief description of the manufacturing, heat treatment and quality control facilities of the manufacturer's work.
- d) Quality Assurance Plan (QAP) enclosed with this tender duly signed, stamped and accepted.

10.2 Within two weeks of placement of order, the manufacturer shall submit 2 copies, of but not limited to, the following drawings, documents and specifications for approval.

- a) Fabrication drawings and relevant calculations for pressure containing parts.
- b) Calculation for the holes/slots sizes/ flow area.
- c) Method of manufacture, welding procedure and heat treatment details.
- d) Quality control Manual.
- e) Type of mill coating / anti-corrosion paint / anti-fouling paint.

Once the approval has been given by Purchaser, any change in design, material method of manufacture shall be notified to Purchaser whose approval in writing of all changes shall be obtained before the flow tees are manufactured.

10.3 Within four weeks from the approval date Manufacturer shall submit one reproducible and 2 copies of the approved drawings, documents and specification as stated in clause 10.2 of this specification.



**SUPPLY OF CARBON STEEL FLANGES AND FITTINGS AT
COTONOU, BENIN OF WEST AFRICA**



Tender Document No:
:A11P/REPL/011/CSF

Date: 31/03/2023

- 10.4** Prior to shipment, Manufacturer shall submit one reproducible and 4 copies of test certificates as listed in clause 7.0 of this specification.
- 10.5** All documents shall be in English Language.

SECTION –III

**DATA SHEETS & SAMPLE QAP FOR CS FITTINGS &
FLANGES**

DATA SHEET FOR FLOW TEE

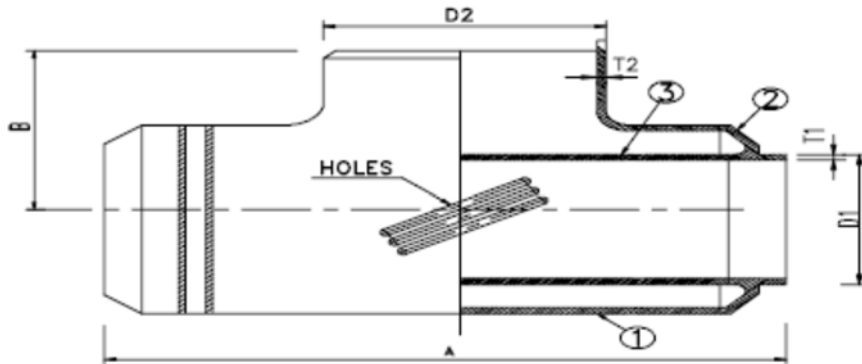

1.	FLOW TEE MFR.	:	* (Vendor to specify)						
2.	PURCHASER'S SPECIFICATION NO	:							
3.	RATING	:	600#						
4.	DESIGN PRESSURE	:	5.4 kg/cm ² (g)						
5.	DESIGN TEMPERATURE	:	-29 to 65 °C						
6.	FLUID IN SERVICE	:	Natural Gas						
7.	CORROSION ALLOWANCE :	:	2 MM						
8.	SIZE NB MM(INCHES)	:	10" X 10"						
9.	END CONNECTION	:	BUTT-WELD AT BOTH ENDS						
10.	DESIGN CODE	:	ASME B31.8						
11.	DESIGN FACTOR	:	0.4						
12.	HYDROSTATIC TEST PRESSURE	:	135 BAR (G) (2.5 times the MAOP for class 4 location)						
13.	CHARPY TEST (TEES, END PIECES)	:	Required at (-) 29°C, CV (Avg.) - 35 J/cm ² / CV (Min.) - 28 J/cm ² (Min. 3 Samples)						
14.	HARDNESS TEST	:	REQUIRED AS PER SPEC						
15.	SUITABILITY OF FLOW TEE	:	For PIGS						
16.	FLOW DIRECTION	:	BI-DIRECTIONAL						
17.	MATERIALS SPECIFICATION (EQUIVALENT OR SUPERIOR)	:							
	1) TEE	:	ASTM A234 Gr. B WPB Sch. STD. 600#						
	2) INTERNAL SLEEVE	:	API 5L Gr. X 60						
17A	T1 & T2		VENDOR TO INDICATE WITH BACKUP CALCULATIONS						
18.	CONNECTING PIPE SPECIFICATION								
	S I N O.	T A G N O.	RUN PIPE DETAILS			BRANCH PIPE DETAILS			QTY N O S.
			D1	THK. (Min.)	MATERIALS	D2	THK. (Min.)	MATERIAL S	
		NB (INCH)	(MM)			NB (INCH)	(MM)		
	1.	To be indicat ed at	10"	9.27	API 5L Sch- 40, X-70	10"	9.27	API 5L Gr.X-70	As per SOR

the time of drg. & document approval to successful bidder on award of work			
19.	SPECIAL REQUIREMENTS	:	INSULATION JOINT SHALL BE SUITABLE FOR ABOVE GROUND INSTALLATION
20	Painting	:	Primer:1 coat of In-organic Zinc silicate @ 65-75 microns DFT Secondary primer: 1 coat of Epoxy Zincphosphate primer @ 40 microns DFT Paint first finish: Two coats of epoxy high buildfinish paint@ each 100 microns DFT i.e 2 x 100 = 200 DFT Paint finish: One coat of Acrylic Poly-urethanepaint @ 40 microns DFT Total DFT 345 micron.

Notes: 1). MANUFACTURE TO INDICATE DIMENSIONS MARKED A & B IN THE SKETCH ABOVE.

2). MANUFACTURER TO FURNISH DETAILS OF THE HOLES IN INTERNAL SLEEVE. THE AREA OF THE HOLES SHALL BE MINIMUM EQUAL TO THE INTERNAL AREA OF THE BRANCH PIPE. RELEVANT CALCULATIONS TO THIS EXTENT SHALL BE FURNISHED.

3). THE WALL THICKNESS OF ALL PARTS OF FLOW TEE SHALL MATCH WITH THE THICKNESS OF THE RUN PIPE & BRANCH PIPE AS INDICATED ABOVE FOR WELDING.

4) VENODR SHALL SUBMIT THE CALCULATION FOR ARRIVING T1 & T2 AS REQUIRED IN 17A) ABOVE.

5) THIS DATA SHEET SHALL BE READ IN CONJUNCTION WITH REPL SPECIFICATION FOR FLOW TEE.

DATA SHEET FOR FLOW TEE

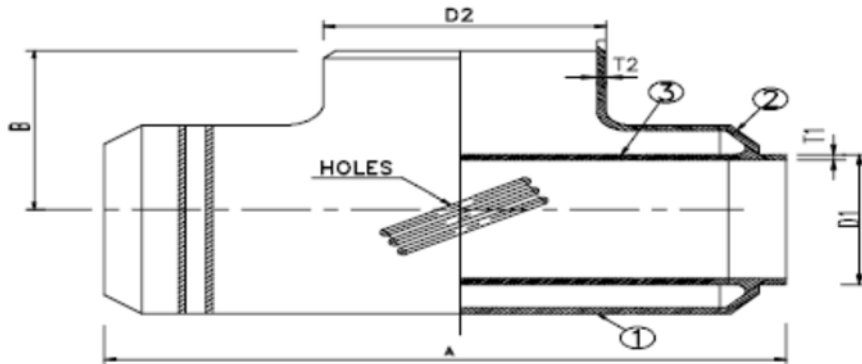

1.	FLOW TEE MFR.	:	* (Vendor to specify)						
2.	PURCHASER'S SPECIFICATION NO	:							
3.	RATING	:	600#						
4.	DESIGN PRESSURE	:	54 kg/cm2(g)						
5.	DESIGN TEMPERATURE	:	-29 to 65 °C						
6.	FLUID IN SERVICE	:	Natural Gas						
7.	CORROSION ALLOWANCE :	:	2 MM						
8.	SIZE NB MM(INCHES)	:	12" X 12"						
9.	END CONNECTION	:	BUTT-WELD AT BOTH ENDS						
10.	DESIGN CODE	:	ASME B31.8						
11.	DESIGN FACTOR	:	0.4						
12.	HYDROSTATIC TEST PRESSURE	:	135 BAR (G) (2.5 times the MAOP for class 4 location)						
13.	CHARPY TEST (TEES, END PIECES)	:	Required at (-) 29°C, CV (Avg.) - 35 J/cm2 / CV (Min.) - 28 J/cm2 (Min. 3 Samples)						
14.	HARDNESS TEST	:	REQUIRED AS PER SPEC						
15.	SUITABILITY OF FLOW TEE	:	For PIGS						
16.	FLOW DIRECTION	:	BI-DIRECTIONAL						
17.	MATERIALS SPECIFICATION (EQUIVALENT OR SUPERIOR)	:							
	1) TEE	:	ASTM A234 Gr. B WPB Sch. STD. 600#						
	3) INTERNAL SLEEVE	:	API 5L Gr. X60						
17A	T1 & T2		VENDOR TO INDICATE WITH BACKUP CALCULATIONS						
18.	CONNECTING PIPE SPECIFICATION								
	SI	TA	RUN PIPE DETAILS	BRANCH PIPE DETAILS	QTY				
	NO.	NO.	D1	THK. (Min.)	MATERIAL S	D2	THK. (Min.)	MATERIAL S	NOS.
			NB (INCH)	(MM)		NB (INCH)	(MM)		
	1.	To be indicated at	12"	8.4	API 5L Gr.X-60	12"	8.4	API 5L Gr.X-60	As per SO R

PREPARED	CHECKED	APPROVED	DATA SHEET NO:	REV: 0
			REPL LIMITED. ALL RIGHTS RESERVED.	

the time of drg. & document approval to successful bidder on award of work			
19.	SPECIAL REQUIREMENTS	:	INSULATION JOINT SHALL BE SUITABLE FOR ABOVE GROUND INSTALLATION
20	Painting	:	Primer: 1 coat of In-organic Zinc silicate @ 65-75 microns DFT Secondary primer: 1 coat of Epoxy Zincphosphate primer @ 40 microns DFT Paint first finish: Two coats of epoxy high build finish paint @ each 100 microns DFT i.e 2 x 100 = 200 DFT Paint finish: One coat of Acrylic Poly-urethane paint @ 40 microns DFT Total DFT 345 micron.

Notes: 1). MANUFACTURE TO INDICATE DIMENSIONS MARKED A & B IN THE SKETCH ABOVE.

2). MANUFACTURER TO FURNISH DETAILS OF THE HOLES IN INTERNAL SLEEVE. THE AREA OF THE HOLES SHALL BE MINIMUM EQUAL TO THE INTERNAL AREA OF THE BRANCH PIPE. RELEVANT CALCULATIONS TO THIS EXTENT SHALL BE FURNISHED.

3). THE WALL THICKNESS OF ALL PARTS OF FLOW TEE SHALL MATCH WITH THE THICKNESS OF THE RUN PIPE & BRANCH PIPE AS INDICATED ABOVE FOR WELDING.

4) VENODR SHALL SUBMIT THE CALCULATION FOR ARRIVING T1 & T2 AS REQUIRED IN 17A) ABOVE.

5) THIS DATA SHEET SHALL BE READ IN CONJUNCTION WITH REPL SPECIFICATION FOR FLOW TEE.

Annexure A : Sample QAP for flanges, SW fittings & BW fittings

QUALITY ASSURANCE PLAN (Flanges)

Client	M/S SIPI-BENIN				QAP NO. & Rev no.			
Consultant	REPL Limited				Date			
Project	Gas Distribution project at Benin of west Africa				LOA NO.			
Material	ASTM A 105				REPL SPEC NO.			
Inspection agency					Page No.		1 of 2	
Components & operation	Characteristics	Type of check	Quantum of check	Code for procedure	Format of record	manufacturer	TPIA	REPL/SIPI
Raw Material inspection								
PIPES /FORGING S/ BARS	chemical	MTC or check test	1 per heat	C≤0.22%, CE ≤0.43%	MTC/CT C	P	R	R
	Dimension, visual & physical	Measurement	100%	FFD	IIR	P	-	-
IN PROCESS CONTROL								
1	Forging	Verification of shape, size & Thk	100%	ASMB B 16.5, API 590	IIR	P	R	R
2	Heat treatment	Normalising	100%	ASTM A105	HT record & Graph	P	R	R
3	Machining	Verification of size	100%	ASMB B 16.5, API 590	IIR	P	R	R
Destructive /Non destructive testing								
4	Mechanical testing	Tensile	1 per heat	ASTM A 370, A105	LR	P	W	W/R
		Hardness	10% per item per size per heat	ASTM A 370, A105	LR	P	W	W/R
		Impact test at (-) 29 ° C (note1)	1 per heat	27 J/cm ² Average & 22J/CM ² (Min.)	LR	P	W	W/R
5	MPI test on finish bevel	MPI test	100%	ASME SEC V/ASME SEC VIII	NDTR	P	10%W	W/R

Annexure A : Sample QAP for flanges, SW fittings & BW fittings

6	Ultrasonic test	Ultrasonic test	100%	ASME SEC V/ASME SEC VIII	NDTR	P	10%W	W/R
Product inspection								
7	Overall dimensional check	Measurement	100%	ASME B 16.5	IIR	P	10%W	W/R
8	Visual check	Visual	100%	FFD, ASME B 16.5	IIR	P	W	W/R
9	Marking	Logo, Material Specification, size, sch/rating, Lot No.	100%		TC	P	10%W	W/R
10	Review of manufacturer's TC and correlation of CTC			Applicable codes	EN 10204 3.2	P	R	R
11	Release Note				IR & IRN		H	R

CTC: Check/Mill test certificate IIR : Internal inspection report R: Review P: Perform		FFD: Free from defects NDTR: NDT Report TC: Test certificate	LR: Lab report H: Hold MPI: Magnetic particle Inspection
---	--	--	--

- WHEN NDT IS PERFORMED BY INDEPENDENT AGENCY LEVEL II PERSONNEL, ONLY REPORT SHALL BE REVIEWED
 - ALL LABS SHALL BE NABL ACCREDITED
 - TEST CERTIFICATE & DOCUMENTS SHALL BE SUBMITTED TO REPL FOR ALL ABOVE TESTS
 - CALIBRATION CERTIFICATES OF ALL MEASURING INSTRUMENTS & GAUGES TO BE SUBMITTED
- Note 1: Impact testing for size 2 inch & above shall be performed.

Sign , stamp & Name of Bidder

Annexure A : Sample QAP for flanges, SW fittings & BW fittings

QUALITY ASSURANCE PLAN (BW FITTINGS)

Client	M/s SIPI-BENIN				QAP NO.& RevNo.			
Consultant	REPL Limited				Date			
Project	Gas Distribution project at Benin, West Africa				LOA NO.			
Material	ASTM A 234 Gr. WPB				REPL SPEC NO.			
Inspection agency					Page No.	1 of 2		
Components & operation	Characteristics	Type of check	Quantum of check	Code for procedure	Format of record	manufacturer	TPIA	REPL/SIPI
Raw Material inspection								
RAW material or pipes	chemical	MTC or checktest	1 per heat	ASME B 16.9, C≤0.22%, CE ≤0.43%	MTC/CTC	P	R	R
	Dimension, visual & physical	Measurement	100%	FFD	IIR	P	-	-
IN PROCESS CONTROL								
1	Forming	Verification of shape, size & Thk	100%	ASME B 16.9	IIR	P	R	R
2	Heat treatment	Normalising	100%	ASTM A234 Gr.WPB	HT record & Graph	P	R	R
3	Machining	Verification of size	100%	ASME B 16.9	IIR	P	R	R
Destructive /Non destructive testing								
4	Mechanical testing	Tensile	1 per heat	ASTM A 370, A234 Gr. WPB	LR	P	W	W/R
		Hardness	10% per item per size per heat	ASTM A 370, A234 Gr. WPB	LR	P	W	W/R
		Impact test at (-) 29 ° C	1 per heat	27 J/cm ² Average & 22 J/CM ² (Min.)	LR	P	W	W/R

Annexure A : Sample QAP for flanges, SW fittings & BW fittings

5	MPI test on finish bevel	MPI test	100%	ASME SEC V/ASME SEC VIII	NDTR	P	10%W	W/R			
6	Ultrasonic test	Ultrasonic test	100%	ASME SEC V/ASME SEC VIII	NDTR	P	10%W	W/R			
Product inspection											
7	Overall dimensional check	Measurement	100%	ASME B16.9	IIR	P	10%W	W/R			
8	Visual check	Visual	100%	FFD, ASME B16.9	IIR	P	W	W/R			
9	Marking	Logo, Material Specification, size, Sch/rating, Lot No.	100%		TC	P	10%W	W/R			
10	Review of manufacturer's TC and correlation of CTC			Applicable codes	EN 10204 3.2	P	R	R			
11	Release Note				IR & IRN		H	R			
<table border="1" style="width: 100%; border-collapse: collapse;"> <tr> <td style="width: 33%; padding: 5px;"> CTC: Check/Mill test certificate IIR : Internal inspection report R: Review P: Perform </td> <td style="width: 33%; padding: 5px;"> FFD: Free from defects NDTR: NDT Report TC: Test certificate </td> <td style="width: 33%; padding: 5px;"> LR: Lab report H: Hold MPI: Magnetic particle Inspection </td> </tr> </table>									CTC: Check/Mill test certificate IIR : Internal inspection report R: Review P: Perform	FFD: Free from defects NDTR: NDT Report TC: Test certificate	LR: Lab report H: Hold MPI: Magnetic particle Inspection
CTC: Check/Mill test certificate IIR : Internal inspection report R: Review P: Perform	FFD: Free from defects NDTR: NDT Report TC: Test certificate	LR: Lab report H: Hold MPI: Magnetic particle Inspection									
<ul style="list-style-type: none"> WHEN NDT IS PERFORMED BY INDEPENDENT AGENCY LEVEL II PERSONNEL, ONLY REPORT SHALL BE REVIEWED. ALL LABS SHALL BE NABL ACCREDITED TEST CERTIFICATE & DOCUMENTS SHALL BE SUBMITTED TO REPL FOR ALL ABOVE TESTS CALIBRATION CERTIFICATES OF ALL MEASURING INSTRUMENTS & GAUGES TO BE SUBMITTED 											

Sign , stamp & Name of Bidder

Annexure A : Sample QAP for flanges, SW fittings & BW fittings

QUALITY ASSURANCE PLAN (FORGED FITTINGS)

Client	M/s SIPI BENIN	QAP NO. & Rev. No.	
Consultant	REPL Limited	Date	
Project	Gas Distribution project at Benin, West Africa	LOA NO.	
Material	ASTM A 105	REPL SPEC NO.	
Inspection agency		Page No.	1 of 2

Components & operation	Characteristics	Type of check	Quantum of check	Code for procedure	Format of record	manufacturer	TPIA	REPL/SIPI
Raw Material inspection								
PIPES /FORGING S/ BARS	chemical	MTC or check test	1 per heat	MSS SP 97 C≤0.22%, CE≤0.43%	MTC/CT C	P	R	R
	Dimension, visual & physical	Measurement	100%	FFD	IIR	P	-	-
IN PROCESS CONTROL								
1	Forming	Verification of shape, size & Thk	100%	MSS SP 97	IIR	P	R	R
2	Heat treatment	Normalising	100%	ASTM A105	HT record & Graph	P	R	R
3	Machining	Verification of size	100%	MSS SP 97	IIR	P	R	R
Destructive /Non destructive testing								
4	Mechanical testing	Tensile	1 per heat	ASTM A 370, A105	LR	P	W	W/R
		Hardness	10% per item per size per heat	ASTM A 370, A105	LR	P	W	W/R
5	MPI test on finish bevel	MPI test	100%	ASME SEC V/ASME SEC VIII	NDTR	P	10%W	W/R

Annexure A : Sample QAP for flanges, SW fittings & BW fittings

6	Ultrasonic test	Ultrasonic test	100%	ASME SEC V/ASME SEC VIII	NDTR	P	10%W	W/R
Product inspection								
7	Overall dimensional check	Measurement	100%	MSS SP 97	IIR	P	10%W	W/R
8	Visual check	Visual	100%	FFD, MSS SP 97	IIR	P	W	W/R
9	Marking	Logo, Material Specification, size, Sch/rating, Lot No.	100%		TC	P	10%W	W/R
10	Review of manufacturer's TC and correlation of CTC			Applicable codes	EN 10204 3.2	P	R	R
11	Release Note				IR & IRN		H	R

CTC: Check/Mill test certificate IIR : Internal inspection report R: Review P: Perform		FFD: Free from defects NDTR: NDT Report TC:Test certificate	LR: Lab report H: Hold MPI:Magnetic particle Inspection
<ul style="list-style-type: none"> • WHEN NDT IS PERFORMED BY INDEPENDENT AGENCY LEVEL II PERSONNEL, ONLY REPORT SHALL BE REVIEWED • ALL LABS SHALL BE NABL ACCREDITED • TEST CERTIFICATE & DOCUMENTS SHALL BE SUBMITTED TO REPL FOR ALL ABOVE TESTS • CALIBRATION CERTIFICATES OF ALL MEASURING INSTRUMENTS & GAUGES TO BE SUBMITTED 			

Sign , stamp & Name of Bidder

Annexure B : Sample QAP for Flow Tee

QUALITY ASSURANCE PLAN

Client	M/s SIPI-BENIN	QAP NO. & Rev no.	
Consultant	REPL Limited	Date	
Project	Gas Distribution project at Benin, West Africa	LOA NO.	
Material	As per Approved GA drg & data sheet	REPL SPEC NO.	

Stage	Components & operation	Characteristics	Method of check	Quantum of check	Reference document & Acceptance	Format of record	manuf acturer	TPI A	GG L/MECON
-------	------------------------	-----------------	-----------------	------------------	---------------------------------	------------------	---------------	-------	------------

Material inspection

Material	Equal /Unequal Tee as per EN 10204,3.2	Visual, Dimension, Finish, Mechanical properties, (Tensile, Impact at -29 ° C, hard ness) , chemical properties, CE, Supply condition (Heat treatment)	Visual, dimensions, verification of markings with MTC, Review MTC	100% for each heat	Applicable material specification, REPL Specification, Approved Drawing CE<=0.45%	MTC	P	W	R
Material	Equal /Unequal Tee as per EN 10204,3.2	Soundness of Tee (NDT)	Ultrasonic test of entire surface	100%	Applicable material specification, REPL Specification, Approved Drawing	NDTR	P	W	R
Material	End cover/ Forged Rings as per EN 10204,3.2	Soundness of End cover (NDT)	Ultrasonic test of entire surface or Review of magnetic particle test reports	100%	Applicable material specification, REPL Specification, Approved Drawing	NDTR	P	W	R

Annexure B : Sample QAP for Flow Tee

Material	Internal Sleeve as per EN 10204, 3.2	Visual, Dimension, Finish, Mechanical properties, (Tensile, Impact at -29 ° C, hardness) ,chemical properties	Visual, dimensions, verification of markings with MTC, Review MTC	100% for each heat	Applicable material specification, REPL Specification, Approved Drawing	MTC	P	W	R
IN PROCESS CONTROL									
In process	Welding procedure specification	Welding parameters	Verification of parameters & mechanical testing/Review of established WPS	100%	ASMB SEC.IX	ASMB SEC.IX 2010 & Addenda 2011	P	Review of existing WPS/PQR by TPIA if suitable, In the non suitability of established WPS/PQR shall be witness by TPIA	R
In process	Welding procedure Qualification Record	Mechanical testing & Welding parameters	Verification of parameters & mechanical testing/Review of established PQR	100%	ASMB SEC.IX	ASMB SEC.IX 2010 & Addenda 2011	P	Review of existing WPS/PQR by TPIA if suitable, In the non suitability of established WPS/PQR shall be witness by TPIA	R
In process	Welder performance Qualification	Welder's ability weld soundness radiography	Verification of parameters & mechanical testing/Review of established WPS	100%	ASME SEC.IX	ASMB SEC.IX 2010 & Addenda 2011	P	Review of existing WPS/PQR by TPIA if suitable, In the non suitability of established WPS/PQR shall	R

Annexure B : Sample QAP for Flow Tee

								be witness by TPIA	
In process	Fill up of Circ.Seam joints	Visual dimension set up	Visual & dimension DP at edges	100%	Approved drg./ASME B31.8	IIR	P	W	R
In process	Internal sleeve weld	Soundness of weld	UT/MPI	100%	ASME SEC.V & ASME SEC.VIII Div I	NDTR	P	W	R
In process	Butt Welds (Tee to forged ends)	Soundness of weld	Radio graphy	100%	ASME SEC.V & ASME SEC.VIII Div I, API 1104	RT Report	P	W	R
In process	Bevel ends	Lamination & other defects	MPI	100%	ASME SEC.V & ASME SEC.VIII Div I	NDTR	P	W	R
In process	Post weld heat treatment	-	Review of heat treatment chart	100%	ASME SEC.VIII Div I / App. Procedure	HT Chart	P	W	R
Final inspection/Testing									
Hydro testing	Flow tees	Soundness of flow tee	Hydro test	100%	Approved Drg/Specification /No leakage/No Distortion	Hydro test report	P	W	W/ R
Final inspection	Hard ness at body, weld & HAZ	Hardness	Measurement	100%	Approved Drg/Specification	Inspection report	P	W	W/ R
Final inspection	Finished weld ends of flow tee	Lamination	Ultrasonic testing (with D meter)	100%	Approved Drg/Specification	Inspection report	P	W	W/ R
Final inspection	Product	Completeness, Visual & Dimensional	Visual & measurement	100%	Approved Drg/Specification	Inspection report	P	W	W/ R
Final inspection	Product	Marking	Visual	100%	REPL TS.	IIR	P	W	W/ R

Annexure B : Sample QAP for Flow Tee

Finishing & painting									
Finishing	Product surface preparation	Surface cleaning	Visual	100%	Approved Drg/Specification	II R	P	W	W/ R
Finishing	Product	Painting (Corrosion resistant paint)	Visual	100%	REPL TS	II R	P	W	W/ R
Final documentation as per EN 10204, 3.2		Record	Check	100%	Approved Drg/Specification	EN 10204 -3.2 Certificate	P	C	H

Notes:

- .All items shall be provided with EN 10204-3.2 Certificates
- WHEN NDT IS PERFORMED BY INDEPENDENT AGENCY LEVEL II PERSONNEL, ONLY REPORT SHALL BE REVIEWED
- ALL LABS SHALL BE NABL ACCREDITED
- TEST CERTIFICATE & DOCUMENTS SHALL BE SUBMITTED TO REPL FOR ALL ABOVE TESTS
- CALIBRATION CERTIFICATES OF ALL MEASURING INSTRUMENTS & GAUGES TOBE SUBMITTED
- Fully killed Carbon steel shall be used in manufacturing of flow tees

LEGENDS:

H-Hold R-Review W-Witness C-Certification R-Review